



Prod.No: 954 00 13-61
 Engine: B & S 28m707 Type: 0178 Trim: 01
 Transaxle/Hydro: Hydro GEAR 310-0500

SPAREPARTS

107 26 47-63

A

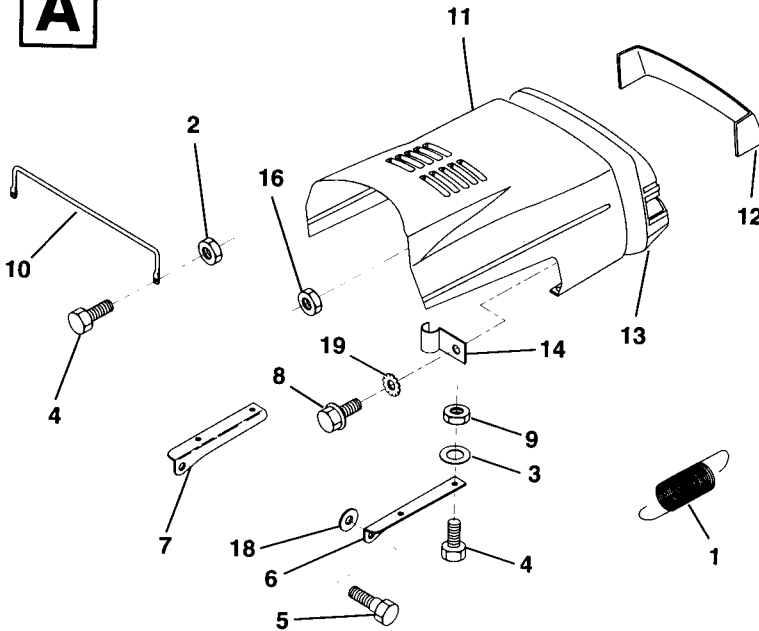

Key No.	Part No.	Description
1	532 12 46-57	Extension, Spring
2	873 64 04-00	Nut, Hex, Keps 1/4-20
3	819 09 14-16	Washer, 9/32 x 7/8 x 16 Ga.
4	874 76 04-12	Bolt, Hex Fin. 1/4-20 x 3/4 Gr. 5
5	532 13 98-88	Bolt, Shoulder
6	532 12 25-49	Bracket, Hood R. H.
7	532 12 25-48	Bracket, Hood L.H.
8	817 52 13-12	Screw Sltd. Hex Hd. w/PL Washer
9	873 68 04-00	Nut Lock w/Insert 1/4-20 UNC
10	532 12 36-93	Brace, Hood
11	532 14 43-43	Hood
12	532 14 01-26	Lens, Plate, Grill
13	532 14 01-11	Grill
14	532 12 49-96	Clip, Line, Fuel
16	532 12 43-46	Nut, Self Thread, Washer Head 1/4
18	734 11 63-01	Washer 11/32 x 11/16 x 16 Ga.
19	810 04 04-00	Washer Lock Ext. 1/4

B

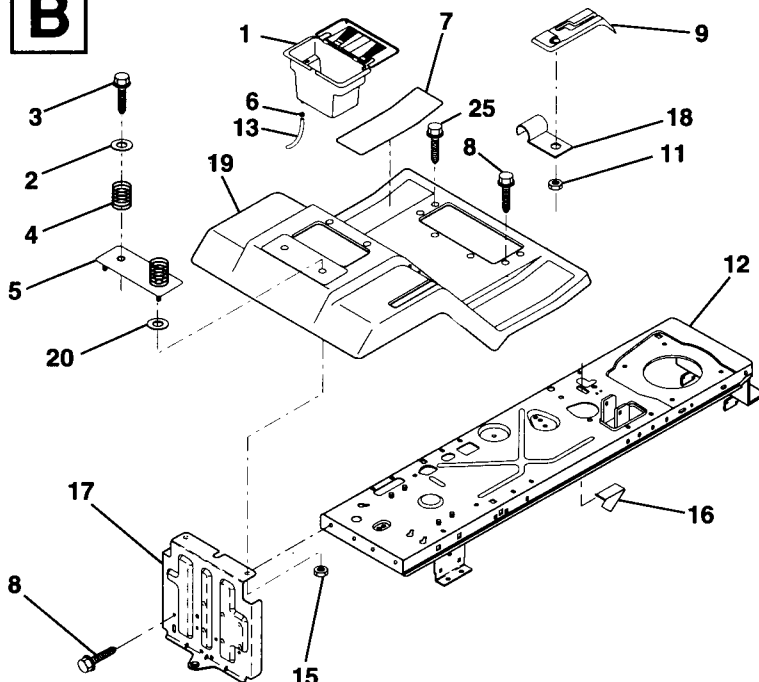

Key No.	Part No.	Description
1	532 14 49-40	Case, Battery
2	734 11 74-41	Washer 13/32 x 1-1/4 x 12 Ga.
3	874 78 06-12	Screw, Hex Wsh. Thrdrol 3/8-16 x 3/4
4	532 12 41-81	Spring, Compression, Seat
5	532 12 71-15	Plate, Asm. Battery
6	532 10 95-96	Clamp, Hose
7	532 12 41-44	Pad, Footrest
8	874 78 05-12	Screw Thdrol 5/16-18 x 3/4
9	532 14 09-19	Console, Shift Control
11	532 12 43-46	Nut, Self-Threading, Wsher Hd 3/16
12	532 14 51-90	Assembly, Frame
13	532 10 92-38	Tube, Battery Drain
15	873 64 04-00	Nut, Keps 1/4-20 UNC
16	532 14 17-36	Switch Actuator
17	532 14 07-82	Drawbar
18	532 12 64-70	Clip, Insulated
19	532 14 12-66	Fender/Footrest
20	819 09 14-16	Washer 9/32 x 7/8 x 13 Ga.
25	817 49 05-18	Scr-Hx S.T. 5/16-18 UNC x 1

C

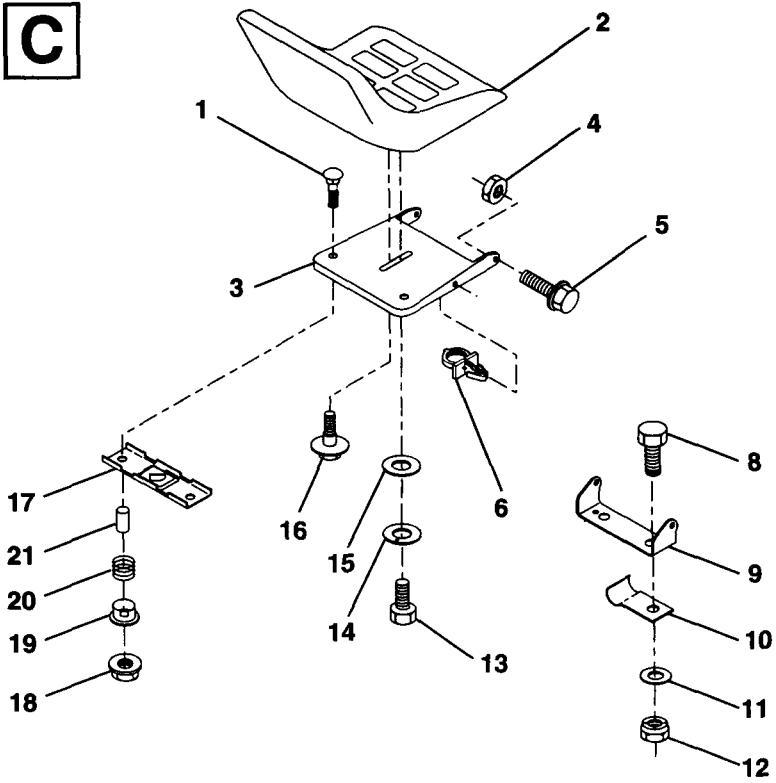

Key No.	Part No.	Description
1	872 05 04-11	Bolt, Carriage 1/4-20 x 1-1/4
2	532 12 74-27	Seat
3	532 14 05-52	Pan, Seat
4	873 80 05-00	Nut, Lock Hex w/Ins. 5/16-18
5	532 13 98-88	Bolt, Shoulder 5/16-18 UNC
6	532 14 50-06	Clip, Push-In
8	874 78 06-16	Bolt, Fin Hex 3/8-16 UNC x 1
9	532 14 05-51	Bracket, Pivot Seat
10	532 12 64-71	Clip Insulated
11	819 13 32-10	Washer 12/32 x 2 x 10 Ga.
12	873 68 06-00	Nut, Lock Hex w/Wsh 3/8-16 UNC
13	874 78 08-14	Bolt, Fin Hex 1/2-13 UNC x 7/8 Gr. 5
14	810 04 08-00	Washer, Lock Hvy Helical Spring
15	819 17 19-12	Washer, 17/32 x 1-3/16 x 12 Ga.
16	532 12 70-18	Bolt, Shoulder
17	532 12 12-46	Bracket, Switch, Mounting
18	873 68 04-00	Nut, Hex Large Flange Lock
19	532 12 12-48	Bushing, Snap
20	532 12 12-50	Spring, Compression
21	532 13 43-00	Spacer, Split 28 Id. x .88 Lg.

D

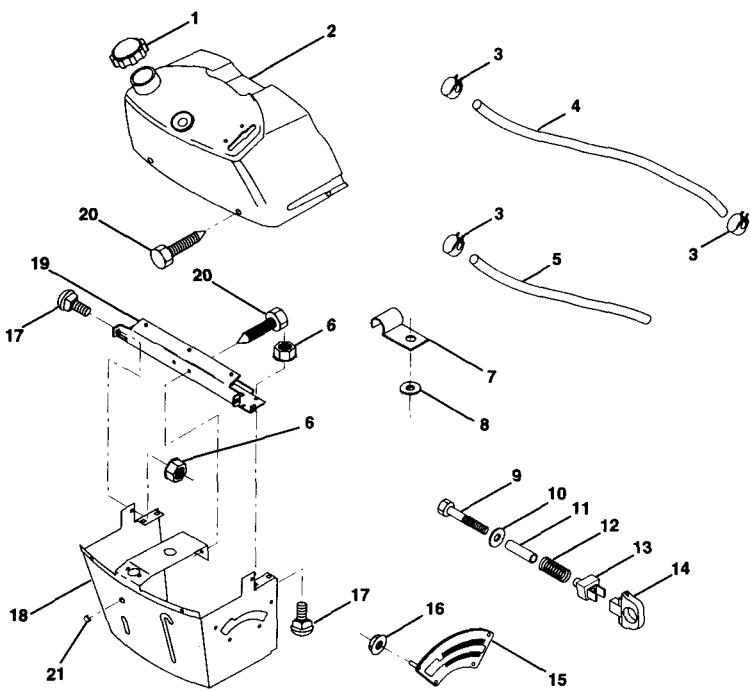

Key No.	Part No.	Description
1	532 14 15-23	Cap, Fuel
2	532 13 83-92	Assembly, Dash & Fuel Tank
3	532 12 34-87	Clamp, Hose
4	532 00 02-95	Line, Fuel
5	532 00 85-48	Line, Fuel
6	873 64 04-00	Nut, Hex, Keps 1/4-20
7	532 00 27-51	Clip, Fuel Line
8	734 11 54-41	Washer 9/32 x 3/4 x 16 Ga.
9	874 76 04-28	Bolt, Hex, Fin 1/4-20 x 1-3/4
10	819 09 14-13	Washer 11/32 x 11/16 x 16 Ga.
11	532 12 12-49	Spacer, Split
12	532 00 37-20	Spring
13	532 12 64-50	Clip, Height Adjustment
14	532 12 61-15	Knob, Height Stop
15	532 12 20-23	Adjustment, Quadrant Height
16	532 12 43-46	Nut, Self-Threading 3/16-18
17	872 11 04-04	Bolt, Carriage 1/4-20 x 1/2 Gr. 5
18	532 13 07-45	Support Assembly, Dash
19	532 13 47-44	Brace, Cross
20	817 06 04-08	Screw, Self-Tapping 1/4-20 x 1/2
21	532 13 40-14	Plug, Dome

HARDWARE SHOWN LARGER FOR EASIER IDENTIFICATION

E

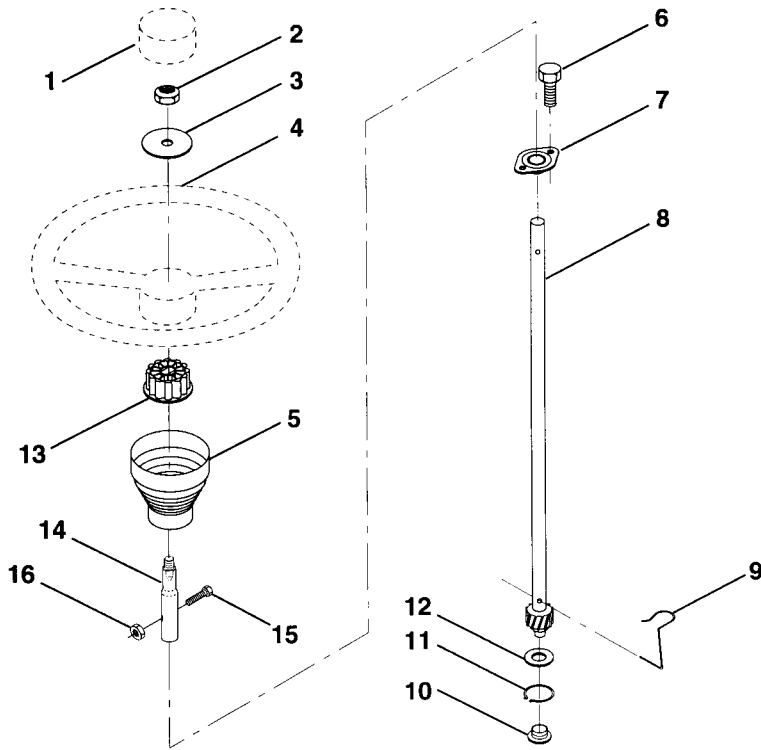

Key No.	Part No.	Description
1	532 14 00-45	Insert, Wheel, Steering
2	873 61 06-00	Nut, Lock 3/8-24 UNF
3	819 13 38-08	Washer 12/32 x 2-3/8 x 8 Ga.
4	532 13 97-68	Wheel, Steering
5	532 12 18-97	Sleeve, Steering
6	817 21 10-08	Screw, Hex #10-16 x 1/2 TY-B
7	532 10 28-03	Bushing, Steering
8	532 14 73-91	Shaft, Steering
9	532 12 42-10	Clip, Steering
10	532 12 34-38	Bushing, Lower, Steering
11	812 00 00-45	Ring, Retaining
12	734 11 85-71	Washer 21/32 x 1 x 16 Ga.
13	532 10 48-20	Adaptor, Wheel, Steering
14	532 14 73-92	Extension, Shaft, Steering
15	874 78 05-20	Bolt, fin., Hex 5/16-18 UNC x 1-1/4
16	873 80 05-00	Nut, Lock, Hex W/Ins. 5/16-18 UNC

G

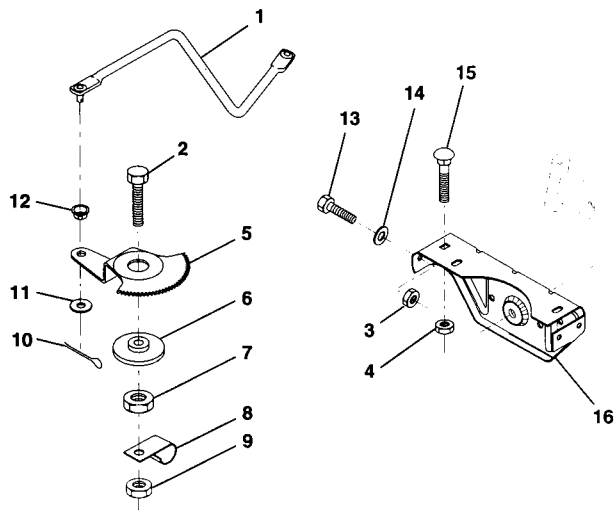

Key No.	Part No.	Description
1	532 13 25-66	Link, Drag
2	874 78 08-28	Bolt, Fin Hex 1/2-13 x 1-3/4
3	873 68 05-00	Nut, Crownlock 5/16-18
4	873 68 06-00	Nut, Crownlock 3/8-16 UNC
5	532 12 19-26	Gear, Sector
6	532 12 19-27	Bushing
7	873 68 08-00	Nut, Hvy Hex Top Lock 1/2-13 UNC
8	532 12 64-72	Clip, Insulated
9	873 68 08-00	Nut, Crownlock 3/8-16
10	876 02 04-12	Pin, Cotter 1/8 x 3/4
11	734 11 72-01	Washer, 13/32 x 13/16 x 16 Ga.
12	532 12 68-47	Bushing
13	874 78 05-12	Bolt, Hex Hd. 5/16-18 UNC x 3/4
14	734 11 65 41	Washer 11/32 x 7/8 x 16 Ga.
15	872 11 06-06	Bolt Carriage 3/8-16 x 3/4
16	532 13 70-96	Support, Front Axle

HARDWARE SHOWN LARGER FOR EASIER IDENTIFICATION

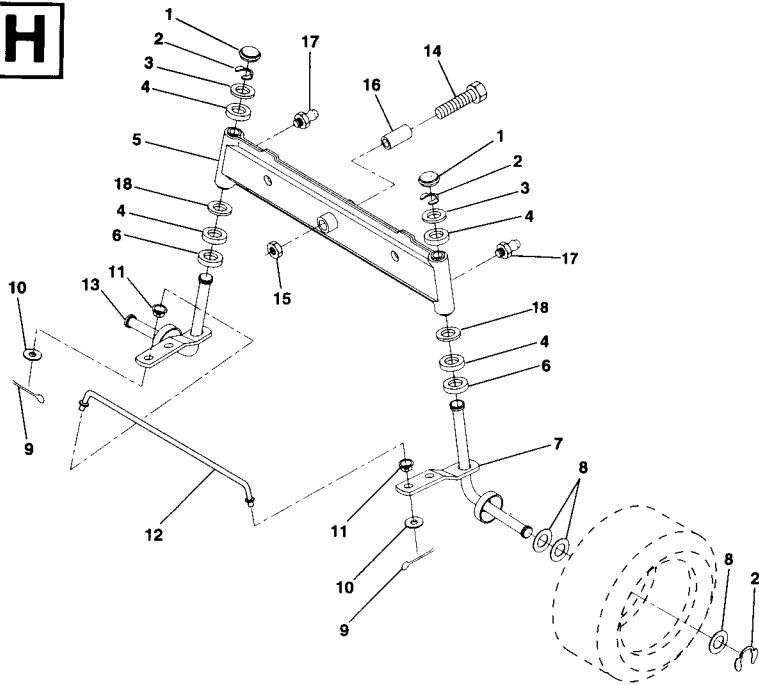
H

Key No.	Part No.	Description
1	532 12 12-32	Cap, Spindle
2	812 00 00-29	Ring, Clip
3	532 12 17-48	Washer 25/32 x 1-5/8 x 16 Ga.
4	532 00 33-66	Bearing Col. Strg.
5	532 14 20-33	Axle, Front
6	532 00 62-66	Bearing, Thrust
7	532 13 70-62	Spindle, R.H. Asm.
8	532 12 17-49	Washer 25/32 x 1-1/4 x 16 Ga.
9	876 02 04-12	Pin, Cotter 1/8 x 3/4
10	734 11 72-01	Washer 13/32 x 13/16 x 16 Ga.
11	532 12 68-47	Bushing
12	532 13 04-65	Rod, Tie
13	532 13 70-61	Spindle, L.H. Asm.
14	874 01 10-56	Bolt Hex 5/8-11 UNC x 3-1/2
15	873 68 10-00	Nut Lock Flange 5/8-11
16	532 11 04-38	Spacer Bearing
17	532 12 48-36	Fitting Grease
18	819 27 20-16	Washer 27/32 x 1-1/4 x 16 Ga.

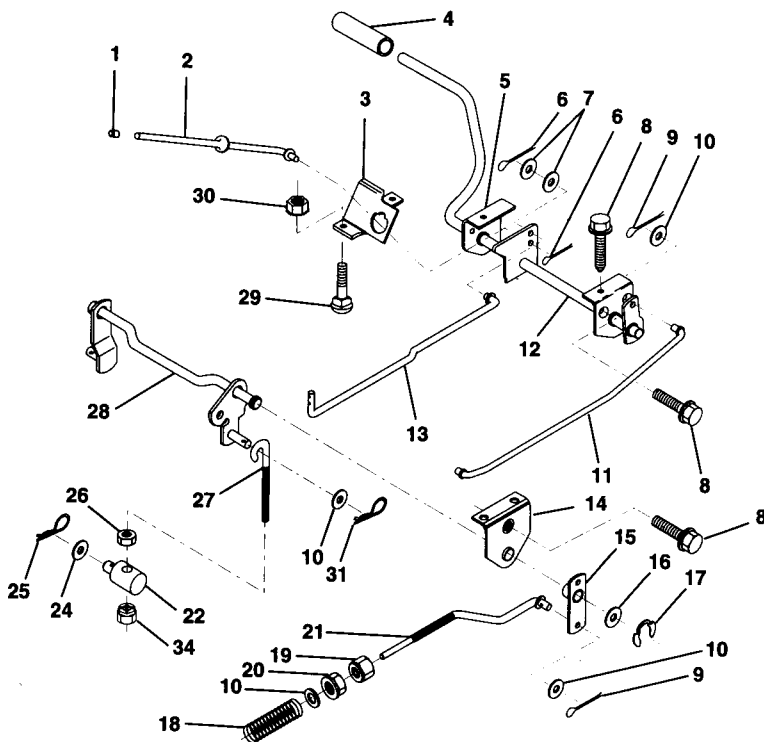
J

Key No.	Part No.	Description
1	532 07 16-73	Cap, Plunger
2	532 12 34-36	Rod, Parking Brake
3	532 12 34-37	Bracket, Parking Brake
4	532 12 48-72	Cover, Pedal
5	532 12 25-04	Bracket, Clutch Pedal, LH
6	876 02 03-12	Pin, Cotter 3/32 x 3/4
7	734 11 71-71	Washer 13/32 x 5/8 x 16 Ga.
8	817 49 05-08	Screw, Hex, Thd. Roll. 5/16-18 x 1/2
9	876 02 04-12	Pin, Cotter 1/8 x 3/4
10	734 11 72-01	Washer 13/32 x 13/16 x 16 Ga.
11	532 12 35-43	Rod, Brake Front
12	532 13 99-33	Assembly, Clutch/Brake Pedal
13	532 12 33-94	Rod, Clutch
14	532 12 19-78	Bracket, Lift, Shaft
15	532 13 33-32	Assembly, Brake, Pivot, Arm
16	819 25 18-16	Washer 25/32 x 1-1/8 x 16 Ga.
17	812 00 00-34	Ring, Klip
18	532 15 13-32	Spring, Brake Rod
19	873 22 06-00	Nut, Hex, Jam 3/8-16 UNC
20	873 80 06-00	Locknut, Hex w/Washer Insert 3/8-16 UNC
21	532 14 44-13	Rod, Brake Hydro
22	532 14 45-85	Trunnion, Lift
24	734 11 74-41	Washer 13/32 x 1-1/4 x 12 Ga.
25	532 00 49-21	Spring, Retainer
26	873 68 06-00	Nut, Centerlock 3/8-16 UNC
27	532 12 73-69	Link, Threaded
28	532 14 07-76	Assembly, Rear Mower Lift
29	872 11 05-06	Bolt, Carriage 5/16-18 UNC x 3/4
30	873 68 05-00	Nut, Keps 5/16-16 UNC
31	532 12 46-60	Spring, Retainer
34	873 68 06-00	Nut, Crownlock 3/8-16 Unc

HARDWARE SHOWN LARGER FOR EASIER IDENTIFICATION

F

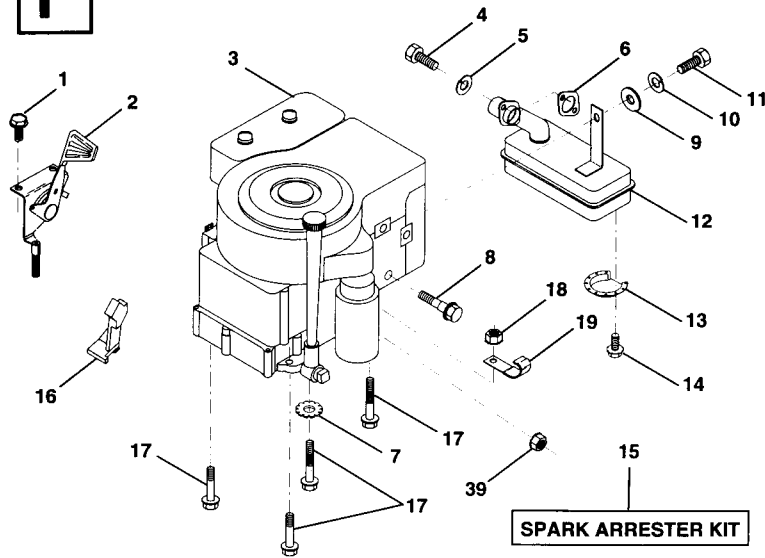

Key No.	Part No.	Description
1	817 06 04-08	Screw, Hex Thd. Cut 1/4-20 x 1/2
2	532 13 30-25	Control, Throttle
3	-----	Engine, B&S 28M707
4	871 07 05-12	Bolt, Hex Head Phillips
5	810 04 05-00	Washer, Lock Hvy Hlcl Spring 5/16
6	532 27 22-93	Gasket, Exhaust
7	810 04 06-00	Washer Lock Ext. Tooth 3/8
8	532 12 10-94	Bolt, Shoulder 5/16
9	819 10 12-16	Washer 5/16 x 3/4 x 16 Ga.
10	810 04 04-00	Washer, Lock Hvy. Helical 1/4
11	-----	Bolt, Hex (Order From Eng. Mfg.)
12	532 13 74-37	Muffler
13	532 10 13-26	Deflector, Muffler
14	817 03 08-08	Screw, Spiderloc
15	532 13 71-80	Arrester, Spark (Optional equipment)
16	532 12 79-51	Stop, Throttle
17	874 78 06-24	Screw, Hex Wsh Hd Thdrol 3/8-16 x 1-1/2
18	873 68 06-00	Nut, Keps, Hex 3/8-16 UNC
19	532 00 27-51	Clip, Fuel Line
39	873 68 04-00	Nut, Flange 1/4-20

K

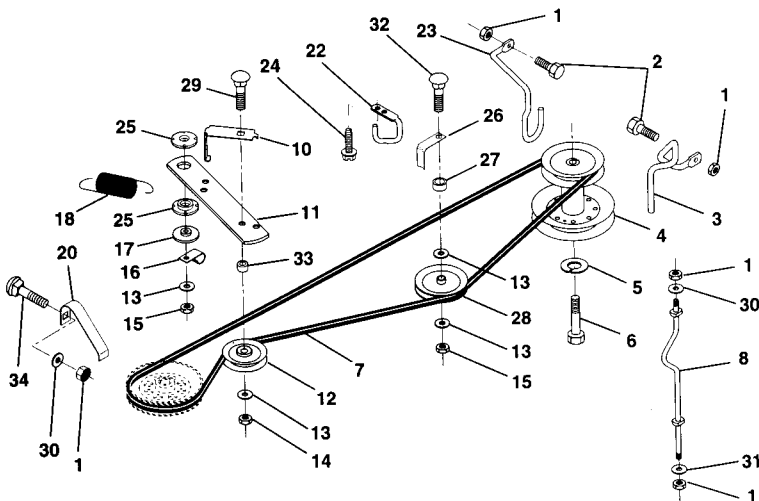

Key No.	Part No.	Description
1	873 80 05-00	Nut, Lock Hex w/Ins 5/16-18
2	874 78 05-12	Bolt, Hex Hd 5/16-18 UNC x 3/4
3	532 14 12-97	Keeper, Belt Front Rh 36" Hydro
4	532 13 80-29	Pulley, Engine 36/38 LR
5	810 04 07-00	Washer, Lock Hvy HLCL SPR 7/16
7	531 02 06-74	V-Belt Ground Drive 77.75 Hyd LR
8	532 14 07-85	Keeper, Belt Rh Hydro LR
10	532 14 07-80	Keeper, Belt Ground Drive Idler LR
11	532 15 09-26	Arm, Ground Drive Clutch LR
12	532 12 36-74	Idler, Flat
13	734 11 72-01	Washer 13/32 x 13/16 x 16 Ga.
14	873 68 06-00	Nut, Centerlock 3/8-16 UNC
15	873 68 06-00	Nut, Crownlock 3/8-16 UNC
16	532 12 64-71	Clip, Insulator 406 MTG Hole
17	532 15 09-32	Spacer, Retainer PM Mower
18	532 13 15-49	Spring Extension
20	532 14 09-09	Keeper, Belt Lh Hodro LR
22	532 12 34-04	Keeper, Frame Ground Drive Belt
23	532 14 09-16	Keeper, Belt Lh Frnt 38/36/H/LR
24	874 78 04-08	Screw, Thd. Cut 1/4-20 x 1/2
25	532 15 09-35	Bushing, Nylon, Collered
26	532 14 09-13	Keeper Belt Idler Fixed Hyd Lr
27	532 14 09-14	Spacer .625 x .843 x .789
28	532 13 91-23	Pulley Idler V-Groove
29	872 14 06-18	Bolt, Carr. 3/8-16 UNC x 2-1/4
30	734 11 63-01	Washer 11/32 x 11/16 x 16 Ga.
31	734 11 63-01	Washer 11/32 x 3/4 x 16 Ga.
32	872 14 06-20	Bolt RDHD SQNK
33	532 00 01-60	Sleeve - Pivot
34	872 14 05-06	Bolt Rdhd Sqnk 5/16 - 18 UNC x 3/4

HARDWARE SHOWN LARGER FOR EASIER IDENTIFICATION

O

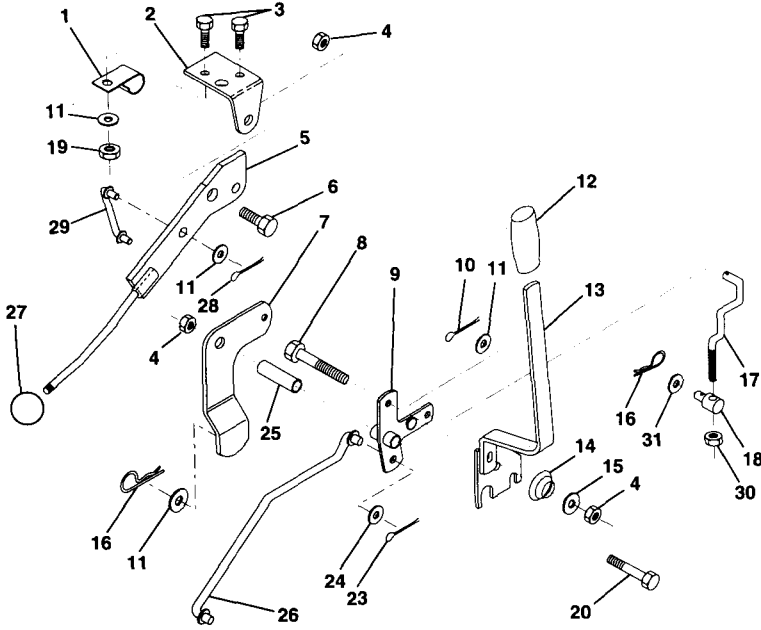

Key No.	Part No.	Description
1	532 12 64-70	Clip, Insulated
2	532 12 20-18	Bracket, Mower Clutch
3	874 78 04-08	Bolt, Fin. Hex 1/4-20 UNC x 1/2
4	873 68 06-00	Nut, Crownlock 3/8-16 UNC
5	532 14 51-87	Assembly, Clutch Lever
6	532 10 64-51	Bolt, Shoulder
7	532 13 53-71	Assembly, Mower Clutch Arm
8	874 76 06-36	Bolt, Hex 3/8-16 UNC x 2-1/4
9	532 12 19-30	Assembly, Bracket Lift
10	876 02 04-12	Pin, Cotter 1/8 x 3/4
11	734 11 72-01	Washer 13/32 x 13/16 x 16 Ga.
12	532 12 20-27	Grip, Handle
13	532 13 93-52	Assembly, Lift Handle
14	532 12 34-96	Spring, Compression
15	734 11 72-01	Washer 13/32 x 3/4 x 12 Ga.
16	532 00 49-21	Retainer, Spring
17	532 12 73-59	Link, Front Lift
18	532 14 20-28	Trunnion, Threaded 3/8-16
19	873 68 04-00	Nut, Crownlock 1/4-20
20	874 76 06-44	Bolt, Fin. Hex 3/8-16 UNC x 2-3/4
23	876 02 04-16	Pin, Cotter 1/8 x 1
24	734 11 78-01	Washer 17/32 x 1 x 12 Ga.
25	532 12 19-33	Tube, Spacer
26	532 14 14-70	Rod, Mower Lift
27	532 12 14-66	Knob
28	876 02 03-12	Pin, Cotter 3/32 x 3/4
29	532 13 16-55	Link, Mower Clutch
30	873 22 06-00	Nut Hex Jam 3/8-16 UNC
31	734 11 74-41	Washer 13/32 x 1-1/4 x 12 Ga.

L

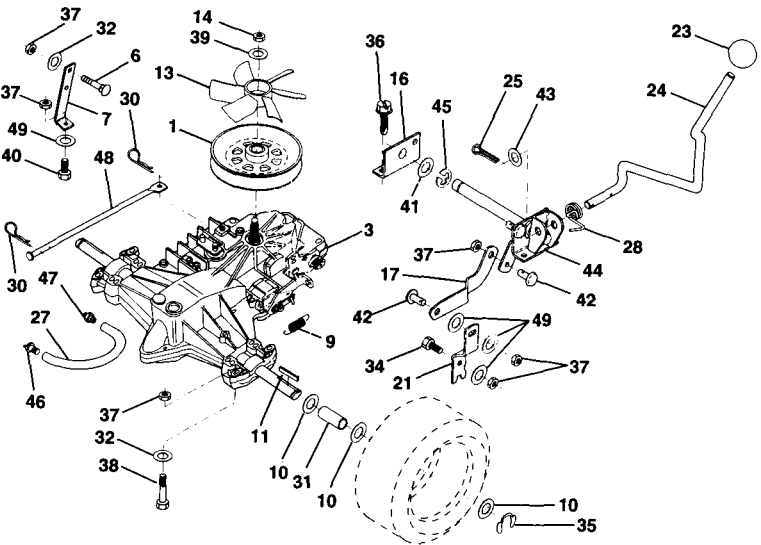

Key No.	Part No.	Description
1	532 14 07-79	Pulley, V-Groove
3	532 14 06-07	Transaxle, Hydro 0310-0500
6	872 14 05-06	Bolt, Carriage 5/16 - 18 x 3/4
7	532 14 07-74	Strap Torque
9	532 14 66-82	Spring Brake
10	532 12 17-49	Washer
11	532 12 35-83	Key Square
13	532 14 07-78	Fan Transaxle Hydro
14	532 00 92-04	Nut
16	532 14 07-63	Support, Shift Handle
17	532 14 07-67	Link Shift
21	532 14 07-73	Lever Shift
23	532 12 12-74	Knob Shifter
24	532 14 07-65	Rob Shifter
25	871 62 04-16	Pin Cotter
27	532 14 25-64	Hose Vent
28	532 14 07-72	Spring Torsion
30	532 12 47-88	Retainer Spring
31	532 12 11-99	Sacer Split
32	734 11 63-01	Washer 11/32 x 11/16 x 16 Ga.
34	874 76 05-16	Bolt Hex Hd 5/16 - 18 x 1
35	812 00 00-01	E-Ring
36	874 78 04-08	Screw, Thd. Cut 1/4-20 x 1/2
37	873 80 05-00	Nut Lock Hex w/Ins 5/16 - 18
38	874 76 05-40	Bolt Hex 5/16-18
39	819 17 19-12	Washer
40	874 76 05-24	Bolt
41	819 21 20-13	Washer
42	532 14 07-69	Pivot Pin
43	819 17 12-16	Washer
44	532 14 07-64	Pivot Shaft Assembly
45	812 00 00 02	E-Ring
46	-----	Cap Bent Hose
47	-----	Nipple Vent Hose
48	532 14 09-12	Actuator Bypass Hydro
49	734 11 63-01	Washer

HARDWARE SHOWN LARGER FOR EASIER IDENTIFICATION

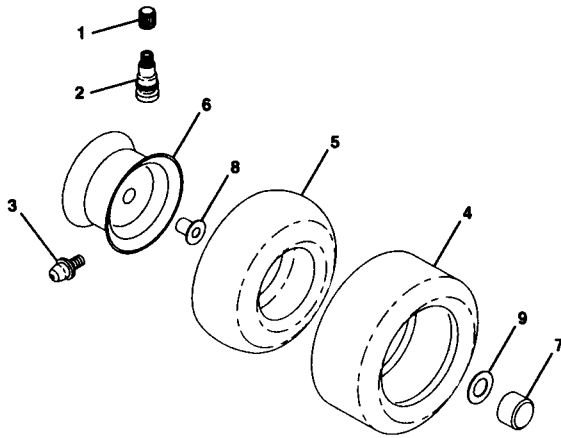
R

Key No.	Part No.	Description
1	532 05 91-92	Cap, Valve
2	532 06 51-39	Stem, Valve
3	352 00 02-78	Fitting, Grease (Front Wheels Only)
4	533 30 11-40	Tire, Front
4	532 13 27-03	Tire, Rear
5	532 05 99-04	Tube, Front (Optional Service Item Only)
5	532 00 81-34	Tube, Rear (Optional Service Item Only)
6	532 14 14-72	Rim, Front
6	532 12 48-44	Rim, Rear
7	532 10 47-57	Cap, Axle
8	532 00 90-40	Bearing, Flange
9	532 12 17-48	Washer 25/32 x 1-5/8 x 16 Ga.

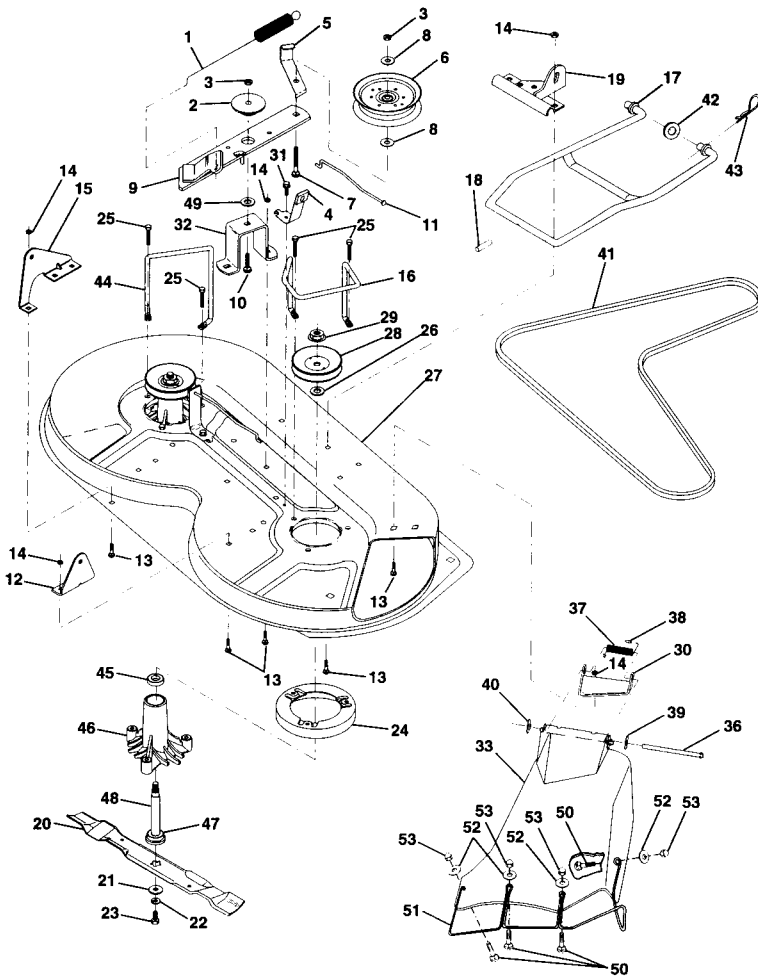
M

Key No.	Part No.	Description
1	532 14 00-64	Spring, Mower Clutch
2	532 12 20-52	Spacer, Retainer
3	873 68 06-00	Nut, Crownlock 3/8-16
4	532 13 08-40	Brake Asm.
5	532 13 12-51	Guide, Belt Idler
6	532 12 13-16	Pulley, Flat Idler
7	872 11 06-16	Bolt, Carr. 3/8-16 x 1-3/4 Gr. 5
8	734 11 72-01	Washer 13/21 x 7/8 x 10 Ga.
9	532 14 00-92	Arm Asm., Idler Mower
10	872 14 06-10	Bolt, Carriage 3/8-16 x 1
11	532 13 08-41	Rod, Brake
12	532 12 73-56	Bracket, Lift R. H. Rear
13	872 14 05-06	Bolt, Carriage 5/16-18 x 3/4
14	873 68 05-00	Nut, Crownlock 5/16-18
15	532 12 73-57	Bracket, Lift L. H. Rear
16	532 14 06-09	Keeper, R. H.
17	532 12 85-08	Link, Asm. Mower Stabilizer
18	532 12 85-11	Pin, Drive
19	532 12 73-80	Bracket, Asm. Front
20	531 02 06-71	Blade, High Performance
21	532 14 02-96	Washer, Hard
22	810 04 06-00	Washer, Lock 3/8
23	532 85 08-57	Bolt 3/8-24 x 1-1/4 Gr. 8
24	532 14 03-29	Stripper
25	532 13 87-76	Screw Thdrol Hex Hd
26	532 12 99-63	Washer .150 Thk.
27	532 12 99-83	Deck Assembly
28	532 12 92-07	Pulley, Mandrel
29	532 13 72-66	Nut, Flangelock 9/16
30	532 13 66-31	Bracket, Asm. Deflector
31	817 49 05-08	Screw, Hex Wsh. Thdrol. 5/16-18 x 1/2
32	532 12 20-51	Arm, Support Idler Mower
33	532 13 90-83	Deflector
36	532 12 19-80	Rod, Hinge
37	532 12 37-13	Spring, Torsion Deflector
38	532 10 53-04	Cap, Sleeve
39	819 11 10-16	Washer 11/32 x 5/8 x 16 Ga.
40	532 11 04-52	Pushnut
41	531 02 06-76	V-Belt
42	734 11 78-01	Washer 11/32 x 5/8 16 Ga.
43	532 12 46-60	Retainer, Spring
44	532 14 06-08	Keeper, L. H.
45	532 11 04-85	Bearing
46	532 12 87-74	Housing Mandrel Vented
47	532 12 98-95	Bearing
48	532 13 76-45	Shaft, Mandrel (Includes Key # 47)
49	532 13 39-43	Washer Hardened
50	871 16 10-10	Screw, Truss, Hd., Phil 10-24 x 5/8
51	532 13 63-83	Guard, Deflector, Mower 36" TUV (W/Form)
52	734 11 46-01	Washer 7/32 x 7/16 x 18 Ga.
53	532 06 08-67	Nut, Acorn, Hex #10-24
---	532 13 07-94	Mandrel Asm. (Includes Key No.'s 22-23, 26, 29 and 45-48)
---	532 14 49-73	Deck, Mower Complete (Std. Deck - Order CE certification components separately, Kit No. EC36)

HARDWARE SHOWN LARGER FOR EASIER IDENTIFICATION

P

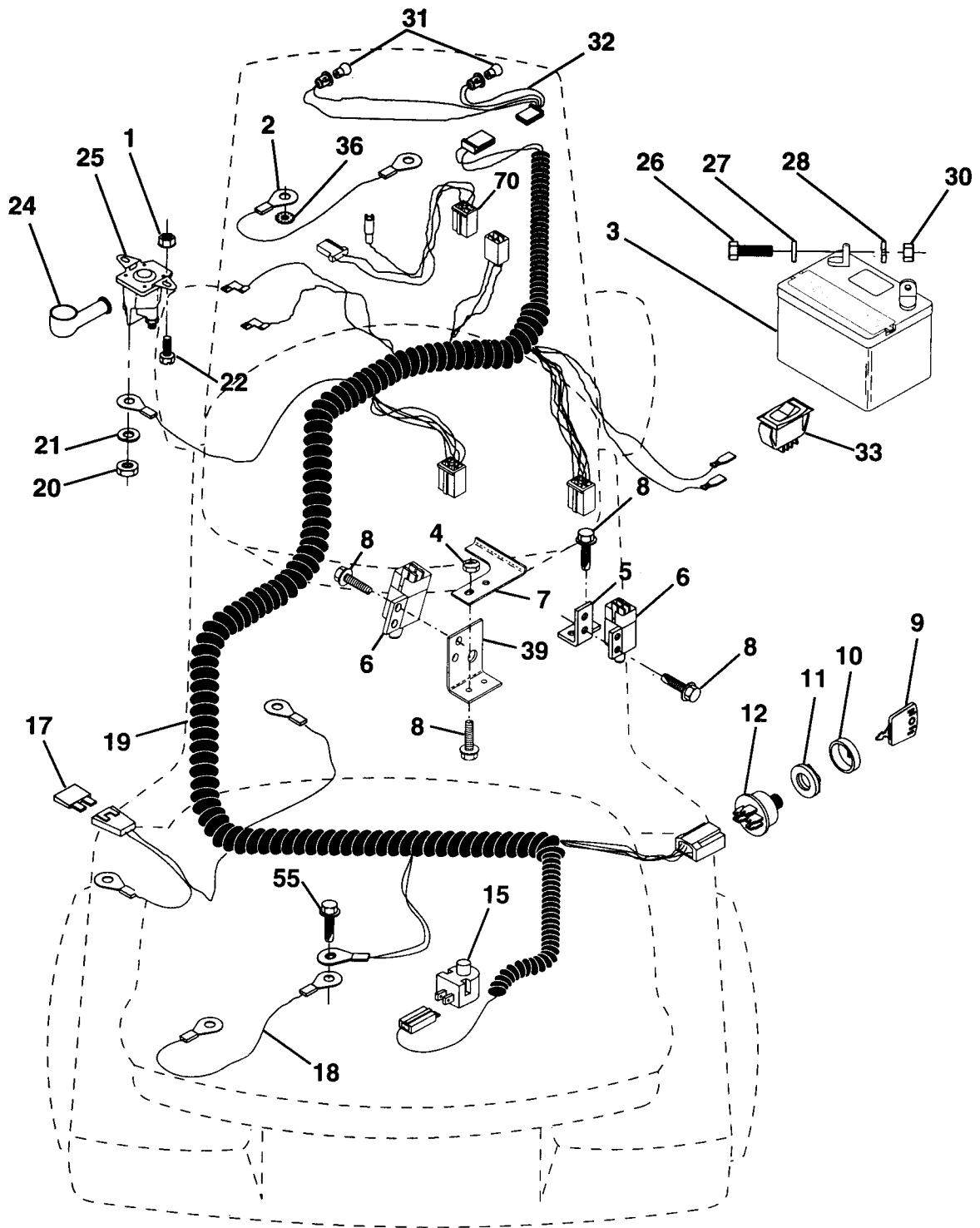

Key No.	Part No.	Description
1	873 22 04-00	Nut, Hex Keps 1/4-20
2	532 10 84-23	Assembly, Cable
3	532 14 61-38	Battery
4	532 06 91-80	Nut, Lock #10-24 UNC
5	532 10 82-36	Bracket, Switch
6	532 10 95-53	Switch, Interlock (4 Terminal)
7	532 14 63-74	Keeper, Actuator
8	817 02 10-08	Screw, Tap Hex Hd.
9	532 14 04-01	Key, Molded
10	532 14 12-26	Cover, Key Ignition
11	532 14 04-00	Nut, Ignition
12	532 14 49-41	Switch, Ignition
15	532 12 13-05	Switch, Plunger
17	532 10 88-24	Fuse
18	532 12 83-53	Assembly, Cable
19	532 14 60-64	Harness, Ignition

Key No.	Part No.	Description
20	873 22 04-00	Nut, Hex Jam 1/4-20
21	810 04 04-00	Washer, Lock 1/4
22	874 78 04-08	Bolt, Fin Hex 1/4-20 UNC x 1/2
24	532 13 15-63	Cover, Terminal
25	532 14 61-54	Solenoid
26	874 76 04-12	Bolt, Hex Hd. 1/4-20 UNC x 3/4
27	734 11 53-01	Washer 9/32 x 5/8 x 16
28	810 04 04-00	Washer, Lock 1/4
30	873 22 04-00	Nut, Fin Hex 1/4-20 UNC
31	532 00 41-52	Bulb, Light
32	532 13 68-50	Harness, Asm., Light
33	532 11 07-12	Switch, Light
36	810 04 04-00	Washer Lock 1/4 Ext.
39	532 14 17-35	Bracket Switch Clutch
55	817 49 05-08	Screw Thdrol 5/16 - 18 x 1/2
70	532 14 04-13	Harness Ignition

HARDWARE SHOWN LARGER FOR EASIER IDENTIFICATION