

**TC
TCP
TCR**

**CATALOGO PEZZI DI RICAMBIO
SPARE PARTS CATALOGUE
CATALOGUE DE PIECES
ERSATZTEILKATALOG**

2000

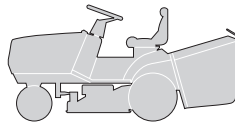

COME USARE IL CATALOGO

HOW TO USE THE CATALOGUE

COMMENT UTILISER LE CATALOGUE

WIE IST DER KATALOG ZU BENUTZEN

1. Generalità

Questo catalogo contiene tutte le informazioni necessarie per ordinare correttamente i pezzi di ricambio.

1. General information

This catalogue contains all the information necessary for correctly ordering spare parts.

1. Généralités

Ce catalogue contient toutes les indications nécessaires pour commander correctement les pièces détachées.

1. Allgemeines

Dieser Katalog enthält alle Informationen, die für die korrekte Bestellung von Ersatzteilen erforderlich sind.

2. Struttura del catalogo

In ogni pagina del catalogo sono riportate le seguenti indicazioni:

2. Structure of the catalogue

Each page of the catalogue has these indications:

2. Structure du catalogue

Les indications suivantes sont reportées sur chaque page du catalogue:

2. Aufbau des Katalogs

Auf jeder Seite des Katalogs sind die folgenden Angaben wiedergegeben:

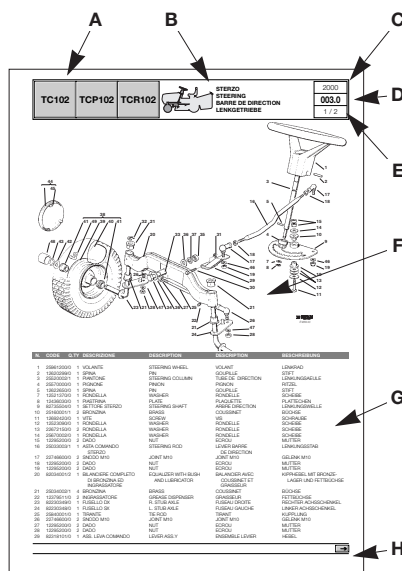

GROUP	DESCRIPTION	DESCRIPTION	DESCRIPTION
20	10000000	1. DADO	SCREW
21	10000000	1. BIELLA	CONN. PIN
22	10000000	1. BIELLA	CONN. PIN
23	10000000	1. BIELLA	CONN. PIN
24	10000000	1. BIELLA	CONN. PIN
25	10000000	1. BIELLA	CONN. PIN
26	10000000	1. BIELLA	CONN. PIN
27	10000000	1. BIELLA	CONN. PIN
28	10000000	1. BIELLA	CONN. PIN
29	10000000	1. BIELLA	CONN. PIN
30	10000000	1. BIELLA	CONN. PIN
31	10000000	1. BIELLA	CONN. PIN
32	10000000	1. BIELLA	CONN. PIN
33	10000000	1. BIELLA	CONN. PIN
34	10000000	1. BIELLA	CONN. PIN
35	10000000	1. BIELLA	CONN. PIN
36	10000000	1. BIELLA	CONN. PIN
37	10000000	1. BIELLA	CONN. PIN
38	10000000	1. BIELLA	CONN. PIN
39	10000000	1. BIELLA	CONN. PIN
40	10000000	1. BIELLA	CONN. PIN
41	10000000	1. BIELLA	CONN. PIN
42	10000000	1. BIELLA	CONN. PIN
43	10000000	1. BIELLA	CONN. PIN
44	10000000	1. BIELLA	CONN. PIN
45	10000000	1. BIELLA	CONN. PIN
46	10000000	1. BIELLA	CONN. PIN
47	10000000	1. BIELLA	CONN. PIN
48	10000000	1. BIELLA	CONN. PIN
49	10000000	1. BIELLA	CONN. PIN
50	10000000	1. BIELLA	CONN. PIN
51	10000000	1. BIELLA	CONN. PIN
52	10000000	1. BIELLA	CONN. PIN
53	10000000	1. BIELLA	CONN. PIN
54	10000000	1. BIELLA	CONN. PIN
55	10000000	1. BIELLA	CONN. PIN
56	10000000	1. BIELLA	CONN. PIN
57	10000000	1. BIELLA	CONN. PIN
58	10000000	1. BIELLA	CONN. PIN
59	10000000	1. BIELLA	CONN. PIN
60	10000000	1. BIELLA	CONN. PIN
61	10000000	1. BIELLA	CONN. PIN
62	10000000	1. BIELLA	CONN. PIN
63	10000000	1. BIELLA	CONN. PIN
64	10000000	1. BIELLA	CONN. PIN
65	10000000	1. BIELLA	CONN. PIN
66	10000000	1. BIELLA	CONN. PIN
67	10000000	1. BIELLA	CONN. PIN
68	10000000	1. BIELLA	CONN. PIN
69	10000000	1. BIELLA	CONN. PIN
70	10000000	1. BIELLA	CONN. PIN
71	10000000	1. BIELLA	CONN. PIN
72	10000000	1. BIELLA	CONN. PIN
73	10000000	1. BIELLA	CONN. PIN
74	10000000	1. BIELLA	CONN. PIN
75	10000000	1. BIELLA	CONN. PIN
76	10000000	1. BIELLA	CONN. PIN
77	10000000	1. BIELLA	CONN. PIN
78	10000000	1. BIELLA	CONN. PIN
79	10000000	1. BIELLA	CONN. PIN
80	10000000	1. BIELLA	CONN. PIN
81	10000000	1. BIELLA	CONN. PIN
82	10000000	1. BIELLA	CONN. PIN
83	10000000	1. BIELLA	CONN. PIN
84	10000000	1. BIELLA	CONN. PIN
85	10000000	1. BIELLA	CONN. PIN
86	10000000	1. BIELLA	CONN. PIN
87	10000000	1. BIELLA	CONN. PIN
88	10000000	1. BIELLA	CONN. PIN
89	10000000	1. BIELLA	CONN. PIN
90	10000000	1. BIELLA	CONN. PIN
91	10000000	1. BIELLA	CONN. PIN
92	10000000	1. BIELLA	CONN. PIN
93	10000000	1. BIELLA	CONN. PIN
94	10000000	1. BIELLA	CONN. PIN
95	10000000	1. BIELLA	CONN. PIN
96	10000000	1. BIELLA	CONN. PIN
97	10000000	1. BIELLA	CONN. PIN
98	10000000	1. BIELLA	CONN. PIN
99	10000000	1. BIELLA	CONN. PIN
100	10000000	1. BIELLA	CONN. PIN

A. Macchina o serie di macchine per le quali la pagina è valida.

A. Machine or machine series to which the page applies.

A. La machine ou la série de machines auxquelles se réfère la page.

A. Maschine oder Serie der Maschine, für welche die Seite gültig ist.

B. Indicazione del gruppo con la raffigurazione in miniatura della sua collocazione sulla macchina.

B. Indication of the unit with a miniature drawing showing its position on the machine.

B. L'indication du groupe avec la représentation en miniature de sa position sur la machine.

B. Bezeichnung der Gruppe mit einer Miniaturdarstellung ihrer Anbringung auf der Maschine.

C. Anno di produzione della macchina a cui si riferisce.

C. Year of production of the machine concerned.

C. L'année de fabrication de la machine concernée.

C. Herstellungsjahr der betreffenden Maschine.

D. Numerazione progressiva della tavola, secondo il seguente criterio:

D. Progressive numbering of the table, arranged as follows:

D. La numérotation progressive du tableau, selon le critère suivant:

D. Progressive Numerierung der Tafel nach folgendem Kriterium:

- le prime due cifre indicano il numero progressivo;
- le eventuali lettere che seguono indicano le diverse versioni alternative di quel gruppo;
- la cifra dopo il punto indica un eventuale aggiornamento nel corso della annualità indicata al punto 3.

- the first two numbers are the progressive number;
- any letters that follow will indicate the various alternative versions of that unit;
- the number after the dot is for any updates during the year given at point 3.

- les deux premiers chiffres indiquent le numéro progressif;
- les éventuelles lettres qui suivent indiquent les différentes versions alternatives de ce groupe;
- le chiffre après le point indique l'éventuelle mise à jour effectuée au cours de l'année indiquée au point 3.

- die ersten zwei Ziffern bezeichnen die progressive Nummer;
- die eventuellen Buchstaben, die folgen, bezeichnen die verschiedenen alternativen Versionen dieser Gruppe;
- die Ziffer nach dem Punkt bezeichnet einen eventuellen neueren Stand im Laufe des Jahrgangs, der in Punkt 3 angegeben ist.

Esempio:

Example:

Exemple

Beispiel:

005a.0 =
005 Gruppo Motore
a 18 HP B&S
.0 Prima stesura

005a.0 =
005 Engine unit
a 18 HP B&S
.0 First copy

005a.0 =
005 Groupe Moteur
a 18 HP B&S
.0 Première rédaction

005a.0 =
005 Motorgruppe
a 18 HP B&S
.0 Erste Ausgabe



E. Numero della pagina e numero totale delle pagine necessarie per la descrizione del gruppo.

E. Page number and total number of pages necessary for the description of the unit.

E. Numéro de la page et nombre total des pages nécessaires pour la description du groupe.

E. Seitenzahl und Gesamtzahl der Seiten, die für die Beschreibung der Gruppe erforderlich sind.

F. Vista esplosa del gruppo.

F. Exploded view of the unit.

F. Vue éclatée du groupe.

F. Explosionszeichnung der Gruppe.

G. Descrizione completa dei singoli particolari, con codice e quantità di pezzi.

G. Full description of each part, with code number and number of pieces.

G. Description complète de chaque élément, avec code et quantité des pièces.

G. Vollständige Beschreibung der Einzelteile, mit Kodenummer und Menge der Teile.

H. Indicazione della presenza di altre pagine di seguito.

H. Indication of additional pages.

H. Indication de la présence d'autres pages successives.

H. Angabe über die Präsenz weiterer folgender Seiten.

Nelle pagine di seguito, sono riportate nuovamente le indicazioni relative ai punti A - C - D - E - G e H.

The additional pages repeat the indications as at points A - C - D - E - G and H.

Les pages qui suivent reportent, elles aussi, les indications concernant les points A - C - D - E - G et H.

Auf den nachfolgenden Seiten sind die Bezeichnungen, die sich auf die Punkte A - C - D - E - G und H beziehen, erneut wiedergegeben.

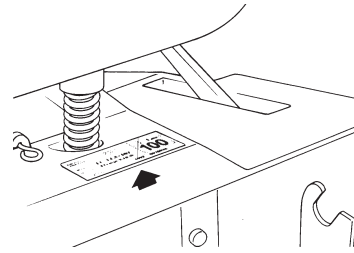
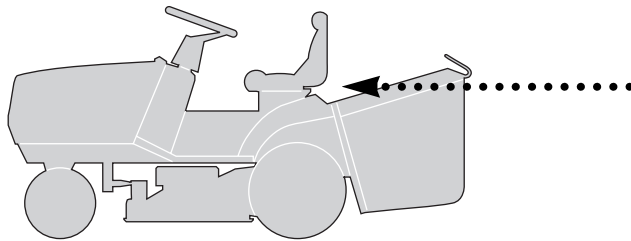

3. Ordine di ricambi

3. Spare parts order

3. Commande pièces détachées

3. Ersatzteilbestellungen

Prima di formulare un ordine di ricambi, accertare che il catalogo corrisponda all'anno di costruzione della macchina, e riportato sulla targhetta di identificazione.

Before putting in an order for spare parts, make sure that the catalogue is the one applying to the machine's year of manufacture, as shown on the identification plate attached to the machine.

Avant de passer une commande pour des pièces détachées, s'assurer que le catalogue est celui correspondant à l'année de fabrication de la machine reportée sur la plaquette d'identification.

Ehe eine Ersatzteilbestellung geschrieben wird, muß man sich vergewissern, daß der Katalog mit dem Herstellungsjahr der Maschine übereinstimmt, oder mit dem auf dem Kennzeichenschild wiedergegeben.

Ogni ordine di ricambi deve necessariamente contenere:

Each spare parts order must include:

Chaque commande de pièces détachées doit obligatoirement contenir:

Jede Ersatzteilbestellung muß enthalten:

- modello della macchina;
- quantità di pezzi richiesta;
- descrizione (eventuale);
- numero di codice del pezzo;
- destinatario
- mezzo di spedizione.

- the model of the machine;
- the number of parts required;
- description (incidental);
- the code number for the item;
- the destination;
- the method of shipping.

- modèle de la machine;
- quantité de pièces demandée;
- description (éventuelle);
- numéro de code de la pièce;
- le destinataire;
- le moyen de transport.

- Modell der Maschine;
- Menge der angeforderten Teile;
- Bezeichnung (eventuell);
- Artikelnummer des Teils;
- Empfänger;
- Versandart.

Esempio di ordinazione:

An example of an order:

Exemple de commande:

Beispiel einer Bestellung:

Su una macchina TCP102 del 2000, con motore B&S da 18 HP si deve sostituire il silenziatore di scarico. Tale particolare è raffigurato nella tavola **005a.0** alla posizione **21**, a cui corrisponde il codice **18716131/1**.

The exhaust pipe silencer on a TCP102 machine, produced in 2000 with an B&S 18 HP engine, must be replaced. This part is shown in table **005a.0** in position **21**, and has the code number **18716131/1**.

Sur une machine TCP102 du 2000, avec moteur B&S de 18 CH, il faut remplacer le silencieux d'échappement. Cette pièce est représentée sur le tableau **005a.0** à la position **21**, correspondant au code **18716131/1**.

Auf einer Maschine TCP102 von 2000, mit Motor B&S mit 18 PS muß der Auspufftopf ersetzt werden. Dieses Einzelteil ist auf der Tafel **005a.0** unter der Position **21** dargestellt, der dem Code **18716131/1** entspricht.

L'ordinazione sarà quindi:

The order will therefore be:

La commande sera donc formulée de la façon suivante:

Die Bestellung lautet demnach:

per TCP102:
n. 1 silenziatore cod. 18716131/1
da inviare a
a mezzo

for TCP102:
1 silencer - code 18716131/1
to be sent to
method of shipping

pour TCP102:
1 silencieux - code 18716131/1
à envoyer à
par

Für TCP102:
1 Auspuff - Kode 18716131/1
zu versenden an
mit

Nota

Note

Remarque

Anmerkung

Per le parti non codificate del motore e della trasmissione contrassegnate con (*), occorre rivolgersi al Costruttore.

For parts of the engine and the transmission without code numbers, marked by (*), it's necessary to contact the manufacturer.

Pour les pièces non codées du moteur et de la transmission, indiquées avec (*), il faut s'adresser au Fabricant.

Für die nicht codierten Teile des Motors und des Antriebs, die mit (*) gekennzeichnet sind, muß man sich an den Hersteller wenden.

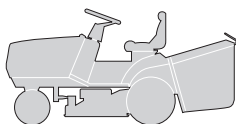
TC102**TCP102****TCR102**
INDICE DELLE TAVOLE
INDEX OF TABLES
SOMMAIRE DES TABLEAUX
INHALT DER TAFELN



2000

000.0

3 / 7

	GRUPPO / UNIT / GROUPE / GRUPPE	TC102	TCP102	TCR102
	CARROZZERIA E CHASSIS BODY AND CHASSIS CARROSSERIE ET CHASSIS KARROSSERIE UND GEHÄUSE	001	001	001
	CRUSCOTTO E SEDILE DASHBOARD AND SEAT TABLEAU COMMANDES ET SIEGE KONSOLE UND SITZ	002	002	002
	STERZO STEERING BARRE DE DIRECTION LENKGETRIEBE	003	003	003
	COMANDO FRENO E COMANDO CAMBIO BRAKE AND GEARBOX CONTROLS COMMANDE FREIN ET BOITE DE VITESSE BREMSE UND WECHSEL ANTRIEB	004	004	004
	MOTORE / ENGINE / MOTEUR / MOTOR 12 - 12,5 - 13 HP B&S	005	005	005
	18 HP B&S	-	005a	-
	15,5 HP B&S	-	005b	-
	13 HP TECUMSEH	005c	-	005c
	15 HP TECUMSEH	005d	-	005d
	TRASMISSIONE TRANSMISSION TRANSMISSION GETRIEBE	006	006	006
	SOLLEVAMENTO PIATTO DI TAGLIO CUTTING PLATE LIFTING SOULEVEMENT PLATEAU DE COUPE SCHNEIDWERKZEUG AUFHEBESATZ	007	007	007
	PIATTO DI TAGLIO (1) CUTTING PLATE (1) PLATEAU DE COUPE (1) SCHNEIDWERKZEUG (1).....	008	008	008
	PIATTO DI TAGLIO (2) CUTTING PLATE (2) PLATEAU DE COUPE (2) SCHNEIDWERKZEUG (2)	009	009	009

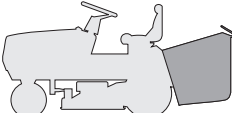
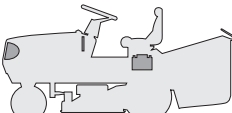

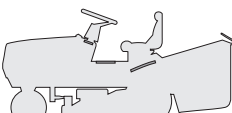
GRUPPO / UNIT / GROUPE / GRUPPE	TC102	TCP102	TCR102
 <p>SACCO GRASSCATCHER BAC AUFFANGSACK</p>	010	010	010
 <p>PARTI ELETTRICHE ELECTRICAL PARTS PARTIES ELECTRIQUES ELETRISCHETEILE</p>	011	011	011
 <p>ACCESSORI A RICHIESTA OPTIONALS ON REQUEST ACCESSOIRES SUR DEMANDE ZUBEHOERE NACH ANFRAGE</p>	012	012	012
 <p>ETICHETTE LABELS ETIQUETTES KLEBZETTEL</p>	013	013	013
<p>SCHEMA ELETTRICO WIRE DIAGRAM SCHEMA ELECTRIQUE ELEKTRISCHES SCHEMA</p>			
<p>12 - 12,5 - 13 HP B&S - 13 - 15 HP TECUMSEH</p>	014	014	014
<p>15,5 HP B&S</p>	-	014a	-
<p>18 HP B&S</p>	-	014b	-

TC102

TCP102

TCR102

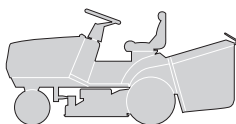

ELENCO NUMERICO
NUMERICAL LIST
LISTE NUMERIQUE
NUMERISCHE AUFSTELLUNG

2000

000.0

5 / 7

CODE	TABLE	N.	Q.TY	CODE	TABLE	N.	Q.TY	CODE	TABLE	N.	Q.TY
12000955/0	007	34	4	12400030/0	010	54	1	12620299/0	003	2	1
12001000/0	003	32	1	12436030/0	003	8	1	12622650/0	003	5	1
12001000/0	003	43	2	12436030/0	009	8	4	12674550/0	008	5	1
12001000/0	004	40	2	12436050/0	001	8	2	12674701/0	010	13	2
12001010/0	006	58	2	12436050/0	009	4	2	12689500/0	004	49	1
12138810/0	006	23	1	12500030/0	009	33	2	12689515/0	004	34	1
12139100/0	009	24	2	12521310/0	002	22	2	12689515/0	005a	10	1
12139480/0	008	52	3	12521330/0	004	16	2	12691100/0	001	26	1
12141418/0	004	47	1	12521330/0	004	35	1	12691100/0	005c	7	4
12150000/0	012	5	1	12521330/0	004	50	2	12691115/0	005	13	4
12154210/0	009	22	6	12521331/0	010	16	6	12691115/0	005a	16	4
12154330/0	002	24	2	12521350/0	002	62	2	12691115/0	005b	7	4
12154330/0	002	49	3	12521350/0	007	21	2	12691200/0	008	46	3
12154330/0	008	70	2	12521350/0	007	31	4	12691700/0	003	30	1
12154510/0	004	10	2	12521350/0	008	20	1	12691700/0	007	30	2
12154510/0	004	36	1	12521350/0	008	41	2	12691700/0	008	45	1
12154510/0	004	51	1	12521350/0	008	47	5	12692080/0	006	8	1
12154510/0	008	6	1	12521370/0	003	7	1	12692420/0	003	11	1
12154510/0	010	20	1	12521390/0	003	36	2	12694100/0	003	34	1
12155000/0	003	31	1	12521410/0	007	17	1	12726388/0	002	19	1
12155000/0	004	13	1	12523020/0	002	14	2	12727810/0	002	28	3
12155000/0	004	15	1	12523060/0	001	36	6	12728099/0	001	25	2
12155000/0	004	7	1	12523060/0	004	6	2	12728440/0	001	22	1
12155000/0	006	11	1	12523060/0	006	13	1	12728440/0	001	29	1
12155000/0	006	14	1	12523060/0	008	21	1	12728440/0	002	6	2
12155000/0	006	21	2	12523060/0	008	74	1	12728440/0	002	9	4
12155000/0	006	42	2	12523070/0	002	64	2	12728440/0	010	55	2
12155000/0	006	44	1	12523070/0	006	34	1	12729601/0	010	12	8
12155000/0	007	22	2	12523070/0	008	77	1	12731580/0	001	40	4
12155000/0	007	32	2	12523080/0	009	28	2	12731601/0	004	4	4
12155000/0	008	48	4	12523090/0	003	12	1	12734995/0	001	31	4
12155000/0	008	75	1	12524010/0	006	43	1	12734995/0	005d	24	1
12155000/0	012	24	3	12540260/0	005	16	2	12735104/0	005	9	1
12155010/0	008	9	1	12540260/0	005	8	1	12735105/0	011	18	3
12156602/0	007	37	4	12540260/0	005a	26	2	12735106/0	005	5	4
12156602/0	009	11	4	12540260/0	005b	8	4	12735106/0	005a	28	4
12290800/0	002	20	1	12540260/0	005c	8	4	12735106/0	005b	22	4
12292100/0	008	19	2	12540260/0	011	33	1	12735106/0	005c	22	4
12292100/0	010	14	4	12540280/0	006	25	1	12735106/0	005c	25	2
12292102/0	002	7	2	12543000/0	006	3	1	12735106/0	005d	21	4
12292102/0	008	58	3	12581200/0	002	23	2	12735108/0	005d	8	1
12292102/0	010	34	2	12582100/0	005a	12	5	12735109/0	005d	7	3
12293200/0	004	44	1	12582101/0	010	15	6	12735110/0	002	4	6
12293200/0	004	46	1	12583500/0	002	59	4	12735110/0	008	60	6
12293200/0	005	14	1	12583500/0	002	63	2	12735110/0	011	8	2
12293200/0	005a	17	1	12583500/0	004	45	1	12735402/0	001	10	4
12293200/0	005b	9	4	12583500/0	005a	20	2	12735402/0	008	92	3
12293200/0	005c	9	1	12583500/0	005a	25	2	12735510/0	005	7	1
12293200/0	006	17	2	12583500/0	005a	7	4	12735530/0	005b	6	2
12293200/0	006	20	2	12583500/0	005b	15	2	12735530/0	005c	6	2
12293200/0	006	37	1	12583500/0	005b	20	2	12735530/0	005d	6	2
12293200/0	008	50	1	12583500/0	005b	5	2	12735530/0	006	27	4
12293201/0	001	14	5	12583500/0	005c	15	2	12735599/0	005a	22	4
12293201/0	001	20	4	12583500/0	005c	20	2	12735599/0	005b	17	4
12293201/0	001	27	1	12583500/0	005c	5	2	12735599/0	005c	17	4
12293201/0	001	37	4	12583500/0	005d	14	2	12735599/0	005d	16	4
12293201/0	002	44	2	12583500/0	005d	19	2	12735694/0	009	29	1
12293201/0	002	51	2	12583500/0	005d	5	2	12735695/1	009	30	1
12293201/0	005	15	3	12583500/0	006	28	4	12737310/0	006	2	1
12293201/0	005a	17	3	12583500/0	008	42	2	12760520/0	012	23	3
12293201/0	006	51	4	12583500/0	008	55	1	12769100/0	012	4	2
12293201/0	007	13	2	12583500/0	008	65	1	12771400/0	008	69	2
12293201/0	008	33	4	12583500/0	008	78	1	12788512/0	002	21	2
12295200/0	001	15	2	12585100/0	001	16	2	12788910/0	002	13	2
12295200/0	003	15	2	12585100/0	003	46	2	12789000/0	002	48	3
12295200/0	003	18	2	12585100/0	003	47	2	12790780/0	002	5	2
12295200/0	003	19	2	12587900/0	003	37	1	12791200/0	010	33	2
12295200/0	003	27	2	12604897/0	002	56	2	12791213/0	005a	11	1
12295200/0	003	28	2	12604899/0	007	9	1	12791213/0	008	7	1
12295200/0	007	36	4	12609200/0	008	38	2	12791400/0	005a	9	3
12295800/0	003	35	1	12609255/0	007	25	2	12792099/0	010	11	4
12360352/0	011	31	2	12609260/0	007	18	1	12792099/0	010	19	1
12360354/1	006	47	4	12609260/0	009	19	2	12792610/0	005a	24	2
12361010/0	006	24	1	12610800/0	008	37	2	12792611/0	001	35	6
12379511/0	003	22	2	12620206/1	007	10	1	12792611/0	002	43	1



CODE	TABLE	N.	Q.TY	CODE	TABLE	N.	Q.TY	CODE	TABLE	N.	Q.TY
12792611/0	005b	19	2	18738212/0	005d	4	1	25160010/0	006	48	2
12792611/0	005c	19	2	19035000/0	009	32	2	25160501/0	009	18	2
12792611/0	005d	18	2	19216032/0	009	17	4	25207000/1	008	68	1
12792611/0	007	12	2	19216033/1	008	36	2	25207200/0	009	16	2
12792611/0	008	32	4	19410603/1	011	14	4	25260000/0	002	10	2
12793101/0	002	58	4	19410604/0	011	21	1	25290000/0	002	15	1
12793101/0	005a	6	4	19410605/1	011	22	1	25318109/0	002	53	1
12793102/0	001	18	1	22034523/0	007	15	3	25318112/0	010	53	1
12793102/0	001	19	2	22061337/0	008	18	1	25318115/1	008	67	1
12793102/0	005a	19	2	22110230/0	003	48	2	25318117/0	004	48	1
12793102/0	005b	14	1	22110230/0	006	61	2	25318120/0	008	1	1
12793102/0	005c	14	2	22160400/0	009	27	2	25318122/0	006	30	2
12793102/0	005d	13	2	22207319/0	006	49	6	25394500/1	004	8	1
12793102/0	008	40	2	22524970/1	002	50	2	25394501/0	002	18	1
12793102/0	008	53	1	22672150/0	003	13	2	25394503/1	008	10	1
12793102/0	008	63	1	22672151/0	008	8	1	25394504/0	007	7	1
12793102/0	008	76	1	22672152/0	006	35	2	25394505/1	004	31	1
12793102/0	009	2	2	22746600/0	003	17	2	25394508/0	010	18	1
12793301/0	006	52	2	22746600/0	003	26	2	25410858/0	001	4	1
12793500/0	002	42	1	22746601/0	004	43	1	25410860/0	001	4	1
12793900/0	008	49	1	22746601/0	006	19	2	25410861/0	001	4	1
12815200/0	008	57	3	22943005/0	006	16	1	25410865/0	001	4	1
12818700/0	009	20	6	24487998/0	012	7	2	25420000/1	011	19	1
12818900/0	008	73	1	24487999/0	012	46	2	25420001/1	011	19	1
12882020/0	006	41	2	25020800/1	009	13	1	25430200/0	011	3	2
14356177/2	013	3	1	25020801/2	009	15	1	25430202/0	002	55	1
14356185/1	013	8	1	25032001/1	010	4	1	25430203/0	002	46	1
14356700/1	013	6	1	25032002/1	010	5	1	25430205/0	002	60	2
14356754/1	013	2	1	25033001/0	007	33	2	25430206/1	008	4	1
14356757/1	013	7	1	25033002/0	007	6	1	25430207/0	006	32	1
14357177/1	013	5	1	25033003/1	003	16	1	25430208/0	007	8	1
14357184/2	013	4	1	25033004/0	004	42	1	25430209/0	003	45	8
14357190/0	013	1	1	25033005/0	004	5	1	25430209/0	006	60	8
15189001/0	006	29	1	25033007/0	004	9	1	25430210/0	008	79	1
16694600/1	006	46	1	25033060/0	009	31	2	25430212/1	004	11	1
18120002/1	011	1	1	25034002/1	003	21	4	25430213/0	004	14	1
18159002/1	006	26	1	25038000/0	008	44	4	25430215/0	002	25	2
18210016/0	011	13	1	25038002/0	006	10	2	25430216/0	012	3	1
18230000/0	011	38	1	25038002/0	009	3	4	25430217/0	001	24	2
18310005/0	005a	27	1	25040601/0	004	41	2	25430218/0	001	23	2
18310005/0	005b	21	1	25040602/0	004	38	2	25430219/0	006	15	1
18310005/0	005c	21	1	25040605/0	007	28	4	25430220/0	010	35	1
18310005/0	005d	20	1	25040607/0	006	31	1	25430223/0	002	66	1
18375051/1	005	3	3	25040608/0	006	39	2	25430224/0	002	47	1
18375051/1	005a	3	1	25060100/2	008	59	1	25430225/0	004	33	1
18375051/1	005b	3	1	25065001/0	011	28	1	25430228/0	001	28	1
18375051/1	005c	3	1	25065002/0	011	29	1	25463200/0	009	23	2
18375051/1	005d	3	1	25065003/0	011	26	1	25470901/0	007	4	1
18375053/0	005	18	1	25065004/0	011	27	1	25485001/0	001	4	1
18375053/0	005a	29	1	25065005/0	011	32	1	25510000/0	002	54	1
18375053/0	005b	23	1	25065009/0	011	39	1	25510006/0	009	7	4
18375053/0	005c	23	1	25065010/1	011	40	1	25510011/0	007	5	1
18375053/0	005d	22	1	25065011/0	011	34	1	25510016/0	002	61	2
18400861/0	011	11	1	25065023/0	011	42	1	25510017/0	004	12	1
18401001/0	005	12	1	25076802/0	001	5	1	25510021/0	012	45	1
18401001/0	005a	15	1	25076808/0	001	5	1	25510022/0	012	6	2
18401001/0	005b	12	1	25090000/0	002	16	1	25510023/1	001	7	2
18401001/0	005c	12	1	25090001/0	002	16	1	25510024/0	009	9	4
18401001/0	005d	11	1	25110166/0	001	9	1	25510039/0	001	7	2
18450060/0	011	6	1	25110174/0	001	9	1	25519997/0	012	22	1
18450065/1	011	10	1	25110175/0	001	9	1	25520002/1	003	3	1
18459100/0	011	4	2	25110176/0	001	9	1	25547012/1	004	3	1
18564861/0	011	35	1	25110218/0	001	9	1	25547014/0	001	3	1
18564862/0	011	2	1	25110260/2	001	11	1	25547014/0	010	10	1
18565351/0	011	12	1	25110261/1	001	12	1	25547015/0	001	3	1
18716131/1	005a	21	1	25110269/0	004	2	1	25547015/0	010	10	1
18716132/0	005b	16	1	25120149/0	002	8	1	25547016/1	001	3	1
18716132/0	005c	16	1	25120150/0	002	8	1	25547016/1	010	10	1
18716132/0	005d	15	1	25122001/0	002	65	2	25547024/0	001	3	1
18736110/0	011	7	1	25122200/1	003	41	4	25547024/0	010	10	1
18737849/0	005	11	1	25122201/0	006	50	3	25547025/0	001	3	1
18737849/0	005a	14	1	25140201/0	006	45	1	25547025/0	010	10	1
18737849/0	005b	11	1	25160001/1	003	10	2	25547026/0	001	3	1
18737849/0	005c	11	1	25160002/0	008	66	1	25547026/0	010	10	1
18737849/0	005d	10	1	25160003/0	008	43	4	25547027/0	001	3	1
18737950/0	012	51	1	25160004/0	007	16	1	25547027/0	010	10	1
18738202/0	005a	4	1	25160005/0	003	33	1	25547028/0	001	3	1
18738203/0	005a	5	1	25160006/0	006	36	1	25547028/0	010	10	1
18738206/0	005b	4	1	25160007/0	008	72	1	25547089/0	001	38	1
18738211/0	005c	4	1	25160008/0	006	9	1	25547091/0	001	39	1

CODE	TABLE	N.	Q.TY	CODE	TABLE	N.	Q.TY	CODE	TABLE	N.	Q.TY
25547093/0	001	3	1	82000401/1	007	14	1	82680006/0	006	54	2
25547093/0	010	10	1	82000483/0	010	31	1	82700000/0	009	6	4
25570000/0	003	4	1	82000590/0	003	39	2	82735502/0	012	42	1
25570001/0	006	38	2	82000592/0	006	55	2	82735504/0	003	9	1
25590000/0	003	40	2	82004340/0	009	26	1	82774207/0	002	41	1
25590001/0	006	56	2	82004341/0	009	25	1	82774209/0	008	2	1
25590002/0	003	40	2	82004600/0	007	19	2	82774225/0	001	34	2
25590003/0	006	56	2	82004601/2	008	11	1	82785021/4	002	1	1
25598002/0	006	18	1	82043101/0	012	44	1	82785022/3	002	2	1
25598050/0	005	10	1	82034001/2	003	20	1	82785023/1	002	3	1
25598050/0	005a	13	1	82040004/1	011	24	1	82785084/1	008	34	1
25598050/0	005b	10	1	82040005/2	011	24	1	82785087/0	002	52	1
25598050/0	005c	10	1	82040024/0	011	23	1	82785089/0	002	45	1
25598050/0	005d	9	1	82040025/0	011	23	1	82785093/0	005a	18	1
25600007/0	011	16	1	82040026/0	011	23	1	82785093/0	005b	13	1
25600009/0	011	16	1	82040028/1	011	25	1	82785093/0	005c	13	1
25600010/0	002	26	1	82040029/1	011	25	1	82785093/0	005d	12	1
25600031/0	005c	24	1	82076801/1	001	2	1	82800002/1	010	3	1
25600038/0	005d	23	1	82076804/0	001	2	1	82800043/0	010	2	1
25600039/0	010	52	1	82076805/0	001	2	1	82800047/0	001	1	1
25600040/0	010	51	1	82076807/0	001	2	1	82869005/0	004	37	1
25600049/0	008	91	1	82076811/0	001	2	1	82869006/0	001	30	1
25601550/0	008	62	1	82076812/0	001	2	1	99900000/0	012	41	1
25601552/2	006	1	1	82076813/0	001	2	1	99900010/1	012	1	1
25601554/0	006	12	1	82076814/0	001	2	1	99900030/5	012	21	1
25601555/0	008	71	1	82076826/0	001	2	1				
25601557/0	007	20	2	82076828/0	001	2	1				
25601559/1	008	35	2	82076840/0	001	2	1				
25601560/0	008	51	2	82076842/0	001	2	1				
25605000/1	007	3	1	82076844/0	001	2	1				
25650021/0	001	17	2	82076846/0	001	2	1				
25650037/0	008	39	1	82106000/2	010	8	1				
25670002/0	003	14	1	82108010/0	009	1	1				
25670005/1	003	42	2	82110170/0	010	9	1				
25670005/1	006	57	2	82110171/0	010	9	1				
25670006/0	004	39	2	82110172/0	010	9	1				
25670007/0	008	54	1	82110173/0	010	9	1				
25670007/0	008	64	1	82110191/0	010	9	1				
25670008/0	007	35	2	82110192/0	010	9	1				
25670008/0	009	10	8	82110193/0	010	9	1				
25670009/0	006	40	2	82110194/0	010	9	1				
25722406/0	011	15	1	82110196/0	010	9	1				
25722407/0	011	15	1	82110250/1	003	44	2				
25722450/0	002	57	1	82110251/1	006	59	2				
25722451/1	002	57	1	82110252/0	003	44	2				
25730000/0	001	6	1	82110253/0	006	59	2				
25730001/0	001	6	1	82180000/2	010	1	1				
25730002/0	001	6	1	82207200/1	009	12	1				
25730003/0	001	6	1	82207201/2	009	14	1				
25735110/2	002	11	1	82230348/0	003	24	1				
25735111/2	002	11	1	82230349/0	003	23	1				
25735501/0	007	11	1	82300000/0	007	1	1				
25774211/1	008	3	1	82318101/0	003	29	1				
25774213/0	012	43	1	82318103/0	007	2	1				
25774220/0	010	32	2	82318105/1	007	23	1				
25774235/0	002	27	1	82318107/1	007	24	1				
25785010/0	011	41	1	82318109/0	007	29	2				
25785095/0	005a	8	1	82318111/1	006	7	1				
25795000/0	002	12	1	82318115/0	007	26	1				
25840001/0	003	25	1	82318117/0	007	27	1				
25869006/0	005	17	1	82318130/0	004	32	1				
25869016/0	005	2	1	82394001/1	010	6	1				
25869016/0	005b	2	1	82400001/1	012	2	1				
25869017/0	005a	2	1	82500001/0	004	1	1				
25869027/0	005c	2	1	82547003/2	008	31	1				
25869027/0	005d	2	1	82547013/0	001	13	1				
25869029/1	010	17	1	82565000/1	009	-	1				
25943002/0	006	33	1	82565005/0	009	5	1				
25950000/0	006	62	2	82597120/0	001	21	1				
25950002/0	003	49	2	82598001/0	005	6	1				
25961200/0	003	1	1	82598005/1	005a	23	1				
33320505/0	011	36	1	82598009/1	005b	18	1				
33320506/0	011	37	2	82598017/0	005c	18	1				
33340033/0	011	20	1	82598019/0	005d	17	1				
33500030/0	011	5	2	82601501/0	006	22	1				
35061501/0	006	6	1	82640001/1	005	4	1				
35062813/0	008	80	1	82650038/0	010	7	1				
35065600/0	008	56	1	82680002/1	003	38	2				
82000200/1	002	17	1	82680003/0	006	54	2				
82000201/1	002	17	1	82680005/1	003	38	2				

TC102

TCP102

TCR102

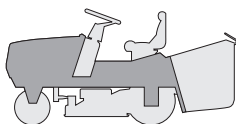

CARROZZERIA E CHASSIS
BODY AND CHASSIS
CARROSSERIE ET CHASSIS
KARROSSERIE UND GEHÄUSE

2000

001.0

1 / 2

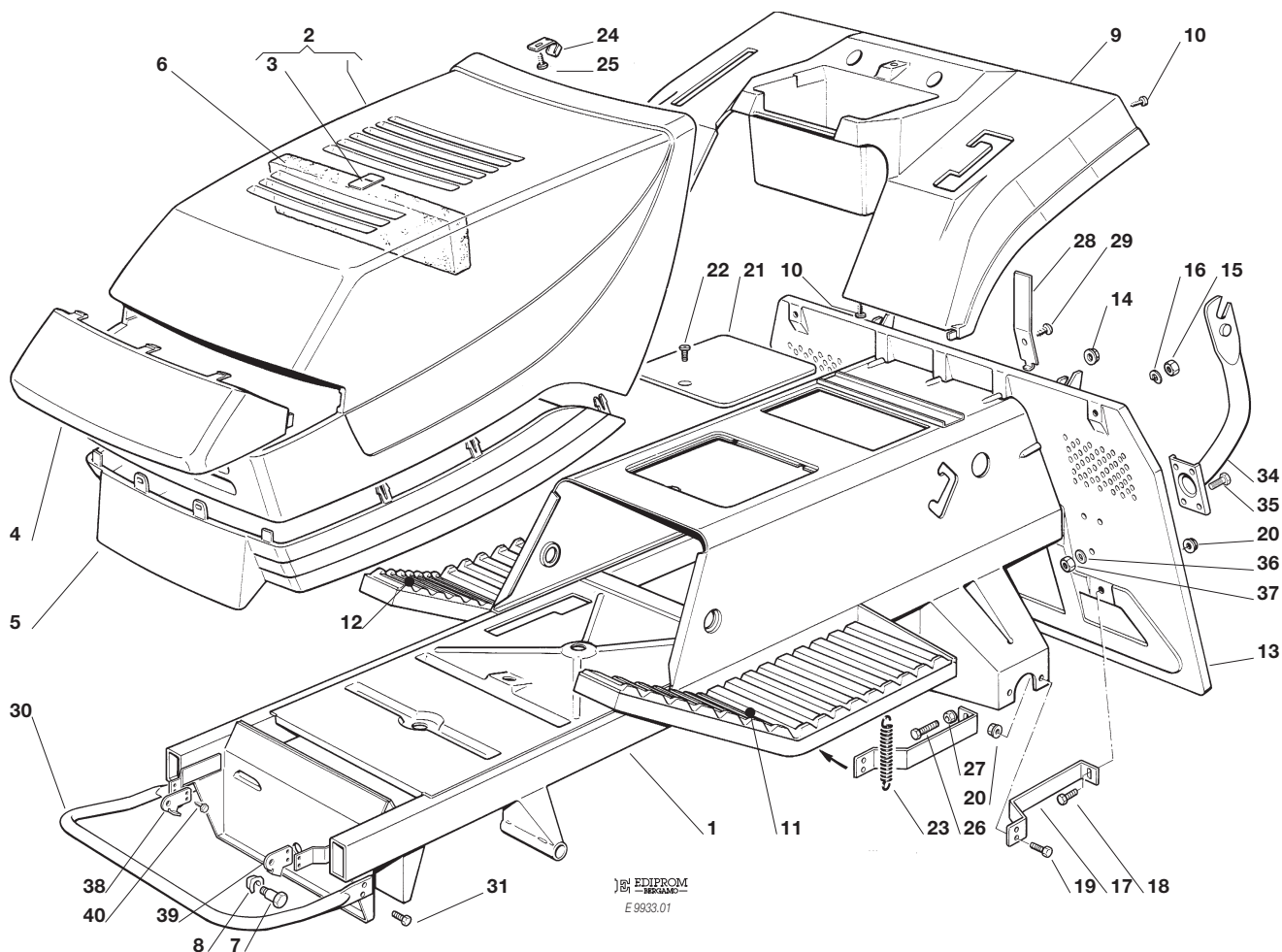

EDIPROM
 BERGAMO
 E 9933.01

N.	CODE	Q.TY	DESCRIZIONE	DESCRIPTION	DESCRIPTION	BESCHREIBUNG
1	82800004/8	1	TELAIO (CON 38 + 39)	CHASSIS (WITH 38 + 39)	CHASSIS (AVEC 38 + 39)	RAHMENSATZ (MIT 38 + 39)
2	82076801/1	1	COFANO SUPER. (TC)	UPPER ENGINE HOOD (TC)	CAPOT SUPERIEURE (TC)	OBERHAUBESATZ (TC)
	82076804/0		ROSSO	RED	ROUGE	ROT
	82076805/0		VERDE	GREEN	VERT	GRÜN
	82076807/0		GIALLO	YELLOW	JAUNE	GELB
	82076807/0		BLU	BLUE	BLEU	BLAU
	82076826/0		ARANCIONE	ORANGE	ORANGE	DUNKELORANGE
	82076840/0	1	COFANO SUPER. (TCP)	UPPER ENGINE HOOD (TCP)	CAPOT SUPERIEURE (TCP)	OBERHAUBESATZ (TCP)
	82076842/0		ROSSO	RED	ROUGE	ROT
	82076844/0		VERDE	GREEN	VERT	GRÜN
	82076844/0		GIALLO	YELLOW	JAUNE	GELB
	82076846/0		BLU	BLUE	BLEU	BLAU
	82076811/0	1	COFANO SUPER. (TCR)	UPPER ENGINE HOOD (TCR)	CAPOT SUPERIEURE (TCR)	OBERHAUBESATZ (TCR)
	82076812/0		ROSSO	RED	ROUGE	ROT
	82076812/0		VERDE	GREEN	VERT	GRÜN
	82076813/0		GIALLO	YELLOW	JAUNE	GELB
	82076814/0		BLU	BLUE	BLEU	BLAU
	82076828/0		ARANCIONE	ORANGE	ORANGE	DUNKELORANGE
3	25547016/1	1	PIASTRINA (TC - TCR)	PLATE (TC - TCR)	PLAQUE (TC - TCR)	PLATTE (TC - TCR)
	25547015/0		ROSSA	RED	ROUGE	ROT
	25547014/0		VERDE	GREEN	VERT	GRÜN
	25547024/0		GIALLA	YELLOW	JAUNE	GELB
	25547024/0		BLU	BLUE	BLEU	BLAU
	25547093/0		ARANCIONE	ORANGE	ORANGE	DUNKELORANGE
	25547025/0	1	PIASTRINA (TCP)	PLATE (TCP)	PLAQUE (TCP)	PLATTE (TCP)
	25547026/0		ROSSA	RED	ROUGE	ROT
	25547027/0		VERDE	GREEN	VERT	GRÜN
	25547027/0		GIALLA	YELLOW	JAUNE	GELB
	25547028/0		BLU	BLUE	BLEU	BLAU
4	25410858/0	1	MASCHERINA (TC)	GRILL (TC)	PANNEAU (TC)	SCHUTZ (TC)
	25410860/0	1	MASCHERINA DX (TCP)	RIGHT GRILL (TCP)	PANNEAU DROITE (TCP)	RECHTE SCHUTZ (TCP)



N.	CODE	Q.TY	DESCRIZIONE	DESCRIPTION	DESCRIPTION	BESCHREIBUNG
	25410861/0	1	MASCHERINA SX (TCP)	LEFT GRILL (TCP)	PANNEAU GAUCHE (TCP)	LINKE SCHUTZ (TCP)
	25410865/0	1	MASCHERINA (TCP)	GRILL (TCP)	PANNEAU (TCP)	SCHUTZ (TCP)
	25485001/0	1	PARABOLA FARI (TCR)	LIGHTS PARABOLA (TCR)	PARABOLE (TCR)	SCHEINWERFERPARABEL (TCR)
5	25076802/0	1	COFANO INFERIORE (TC)	LOWER ENGINE HOOD (TC)	CAPOT INFERIEURE (TC)	UNTERHAUBESATZ (TC)
	25076808/0	1	COFANO INFERIORE (TCP)	LOWER ENGINE HOOD (TCP)	CAPOT INFERIEURE (TCP)	1 UNTERHAUBESATZ (TCP)
6	☛	1	SEPARATORE ASPIRAZ.	INTAKE SEPARATOR	SEPARATEUR ASPIRATIONS	AUGENABSCHIEDER
	25730000/0		TC - 13 HP TECUMSEH	TC - 13 HP TECUMSEH	TC - 13 HP TECUMSEH	TC - 13 HP TECUMSEH
			15,5 - 16 HP B&S	15,5 - 16 HP B&S	15,5 - 16 HP B&S	15,5 - 16 HP B&S
	25730001/0		15 HP TECUMSEH	15 HP TECUMSEH	15 HP TECUMSEH	15 HP TECUMSEH
	25730002/0		TCP - 12,5-13-18 HP B&S	TCP - 12,5-13-18 HP B&S	TCP - 12,5-13-18 HP B&S	TCP - 12,5-13-18 HP B&S
7	25510023/1	2	PERNO (TC - TCP)	PIN (TC - TCP)	PIVOT (TC - TCP)	BOLZEN (TC - TCP)
	25510039/0	2	PERNO (TCR)	PIN (TCR)	PIVOT (TCR)	BOLZEN (TCR)
8	12436050/0	2	PIASTRINA	PLATE	PLAQUE	PLATTE
9	☛	1	COPERTURA RUOTE	WHEELS COVER	COUVRE-ROUES	RADENKAPPE
	25110166/0		ROSSA	RED	ROUGE	ROT
	25110175/0		VERDE	GREEN	VERT	GRÜN
	25110174/0		GIALLO	YELLOW	JAUNE	GELB
	25110176/0		BLU	BLUE	BLEU	BLAU
	25110218/0		ARANCIONE	ORANGE	ORANGE	DUNKELORANGE
10	12735402/0	4	VITE	SCREW	VIS	SCHRAUBE
11	25110260/2	1	COPRIPEDANA SX	LEFT FOOTBOARD COVER	COUVRE MARCHEPIED	LINKE FUSSBRETTDECKEL
				GAUCHE		
12	25110261/1	1	COPRIPEDANA DX	RIGHT FOOTBOARD COVER	COUVRE MARCHEPIED	RECHTE FUSSBRETTDECKEL
				DROITE		
13	82547013/0	1	PIASTRA POST.	REAR PLATE	PLAQUE POSTERIEURE	HINTERPLATTE
14	12293201/0	5	DADO	NUT	ECROU	MUTTER
15	12295200/0	2	DADO	NUT	ECROU	MUTTER
16	12585100/0	2	GROWER	GROWER	GROWER	GROWER
17	25650021/0	2	RINFORZO PIASTRA POST.	REAR PLATE STIFFENING	RENFORCEMENT PLAQUE	HINTERPLATTEVERSTA- ERKUNG
				POST.		
18	12793102/0	1	VITE	SCREW	VIS	SCHRAUBE
19	12793102/0	2	VITE	SCREW	VIS	SCHRAUBE
20	12293201/0	4	DADO	NUT	ECROU	MUTTER
21	82597120/0	1	PORTINA	HANDHOLE	GRILLE	GITTER
22	12728440/0	1	VITE	SCREW	VIS	MUTTER
23	25430218/0	2	MOLLA	SPRING	RESSORT	FEDER
24	25430217/0	2	MOLLA AGGANCI (TCP)	COUPLING SPRING (TCP)	RESSORT ACCROCHA (TCP)	GEKUPPLUNGSFEDER (TCP)
25	12728099/0	2	VITE (TCP)	SCREW (TCP)	VIS (TCP)	SCHARUBE (TCP)
26	12691100/0	1	VITE	SCREW	VIS	SCHRAUBE
27	12293201/0	1	DADO (TCP)	NUT (TCP)	ECROU (TCP)	MUTTER (TCP)
28	25430228/0	1	MOLLA	SPRING	RESSORT	FEDER
29	12728440/0	1	VITE	SCREW	VIS	SCHRAUBE
30	82869006/0	1	PROTEZIONE SILENZIATORE	MUFFLER PROTECTION	PROTECTION SILENCIEUX	AUSPUFFSCHUTZ
31	12734995/0	4	VITE	SCREW	VIS	SCHRAUBE
34	82774225/0	2	SUPPORTO	SUPPORT	SUPPORT	HALTER
35	12792611/0	6	VITE	SCREW	VIS	SCHRAUBE
36	12523060/0	6	RONDELLA	WASHER	RONDELLE	SCHEIBE
37	12293201/0	4	DADO	NUT	ECROU	MUTTER
38	25547089/0	1	PIASTRINA DESTRA	RIGHT PLATE	PLAQUE DROITE	RECHTE PLATTE
39	25547091/0	1	PIASTRINA SINISTRA	LEFT PLATE	PLAQUE GAUCHE	LINKE PLATTE
40	12731580/0	4	VITE	SCREW	VIS	SCHRAUBE

TC102

TCP102

TCR102

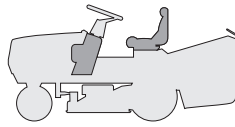

CRUSCOTTO E SEDILE
DASHBOARD AND SEAT
TABLEAU COMMANDES ET SIEGE
KONSOLE UND SITZ

2000

002.0

1 / 2

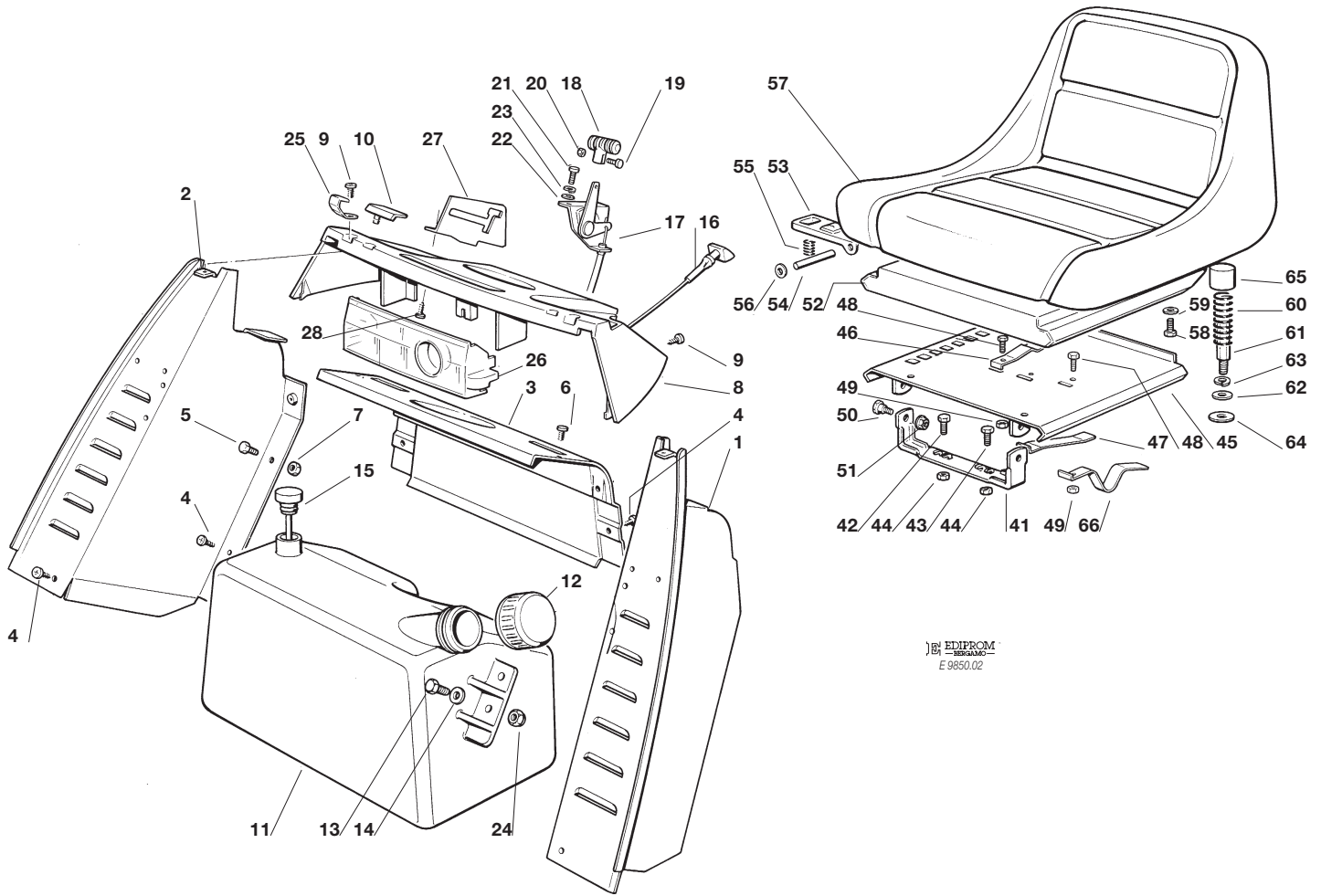

EDIPROM
 E 9830.02

N.	CODE	Q.TY	DESCRIZIONE	DESCRIPTION	DESCRIPTION	BESCHREIBUNG
1	82785021/4	1	SUPP. CRUSCOTTO SX	LEFT DASHBOARD SUPP.	SUPPORT TABLEAU GAUCHE	LINKER KONSOLEHALTER
2	82785022/3	1	SUPP. CRUSCOTTO DX	RIGHT DASHBOARD SUPP.	SUPPORT TABLEAU DROITE	RECHTER KONSOLEHALTER
3	82785023/1	1	SUPP. CRUSCOTTO CENTR. SUPP.	CENTRAL DASHBOARD CENTRAL HALTER	SUPPORT TABLEAU CENTRAL HALTER	ZENTRALER KONSOLE HALTER
4	12735110/0	6	VITE	SCREW	VIS	SCHRAUBE
5	12790780/0	2	VITE	SCREW	VIS	SCHRAUBE
6	12728440/0	2	VITE	SCREW	VIS	SCHRAUBE
7	12292102/0	2	DADO	NUT	ECROU	MUTTER
8	25120149/0	1	CRUSCOTTO (TC - TCR)	DASHBOARD (TC - TCR)	TABLEAU DE BORD (TC - TCR)	KONSOLE (TC - TCR)
	25120150/0	1	CRUSCOTTO (TCP)	DASHBOARD (TCP)	TABLEAU DE BORD (TCP)	KONSOLE (TCP)
9	12728440/0	4	VITE	SCREW	VIS	SCHRAUBE
10	25260000/0	2	GOMMINO	GROMMET	PROTECTION	SCHUTZ
11	25735110/2	1	SERBATOIO	TANK	RESERVOIR	TANK
			12-12,5-13 -15,5 HP B&S	12-12,5-13 -15,5 HP B&S	12-12,5-13 -15,5 HP B&S	12-12,5-13 -15,5 HP B&S
			13 - 15 HP TECUMSEH	13 - 15 HP TECUMSEH	13 - 15 HP TECUMSEH	13 - 15 HP TECUMSEH
	25735111/2	1	SERBATOIO (18 HP B&S)	TANK (18 HP B&S)	RESERVOIR (18 HP B&S)	TANK (18 HP B&S)
12	25795000/0	1	TAPPO	CAP	BOUCHON	TANKVERSCHLUSS
13	12788910/0	2	VITE	SCREW	VIS	SCHRAUBE
14	12523020/0	2	RONDELLA	WASHER	RONDELLE	SCHEIBE
15	25290000/0	1	INDICATORE LIVELLO 18 HP B&S	FUEL LEVEL INDICATOR 18 HP B&S	INDICATEUR NIVEAU 18 HP B&S	KRAFTSTOFFMESSER 18 HP B&S
16	25090000/0	1	COMANDO STARTER 18 HP B&S	STARTER DRIVE 18 HP B&S	COMMANDE STARTER 18 HP B&S	STARTER BETAETIGUNG 18 HP B&S
17	82000200/1	1	ACCELERATORE 12-12,5-13 -15,5 HP B&S 13 - 15 HP TECUMSEH	ACCELERATOR 12-12,5-13 -15,5 HP B&S 13 - 15 HP TECUMSEH	ACCELERATEUR 12-12,5-13 -15,5 HP B&S 13 - 15 HP TECUMSEH	GAS ZUG 1 12-12,5-13 -15,5 HP B&S 13 - 15 HP TECUMSEH
	82000201/1	1	ACCELERATORE 18 HP B&S	ACCELERATOR 18 HP B&S	ACCELERATEUR 18 HP B&S	GAS ZUG 18 HP B&S
18	25394501/0	1	MANOPOLA	HANDLE	POIGNE	GRIF
19	12726388/0	1	VITE	SCREW	VIS	SCHRAUBE



N.	CODE	Q.TY	DESCRIZIONE	DESCRIPTION	DESCRIPTION	BESCHREIBUNG
20	12290800/0	1	DADO	NUT	ECROU	MUTTER
21	12788512/0	2	VITE	SCREW	VIS	SCHRAUBE
22	12521310/0	2	RONDELLA	WASHER	RONDELLE	SCHEIBE
23	12581200/0	2	GROWER	GROWER	GROWER	GROWER
24	12154330/0	2	DADO	NUT	ECROU	MUTTER
25	25430215/0	2	MOLLA AGGANCIO (TC - TCR)	COUPLING SPRING (TC - TCR)	RESSORT ACCROCHAGE (TC - TCR)	KUPPLUNGSFEDER (TC - TCR)
26	25600010/0	1	PROTEZIONE SCHEDA	CARD PROTECTION	PROTECTION DE CARTE	KARTESCHUTZ
27	25774235/0	1	STAFFA GUIDA	PLATE	ETRIER	BRIDE
28	12727810/0	3	VITE	SCREW	VIS	SCHRAUBE
41	82774207/0	1	STAFFA SUPP. SEDILE	SEAT CLAMP SUPPORT	ETRIER SUPPORT SIEGE	BRIDE F. SITZHALTER
42	12793500/0	1	VITE	SCREW	VIS	SCHRAUBE
43	12792611/0	1	VITE	SCREW	VIS	SCHRAUBE
44	12293201/0	2	DADO	NUT	ECROU	MUTTER
45	82785089/0	1	SUPP. SEDILE FISSO	FIXED SEAT SUPP.	SUPPORT SIEGE FIXE	FEST SITZHALTER
46	25430203/0	1	MOLLA ARRESTO	SPRING	RESSORT D'ARRET	RASTFEDER
47	25430224/0	1	MOLLA COMANDO	SPRING	RESSORT DE COMMANDE	FEDER
48	12789000/0	3	VITE	SCREW	VIS	SCHRAUBE
49	12154330/0	3	DADO	NUT	ECROU	MUTTER
50	22524970/1	2	PERNO	PIN	PIVOT	BOLZEN
51	12293201/0	2	DADO	NUT	ECROU	MUTTER
52	82785087/0	1	SUPPORTO SEDILE	SEAT SUPPORT	SUPPORT SIEGE	SITZHALTER
53	25318109/0	1	LEVA ARRESTO	STOP LEVER	LEVIER D'ARRET	ABSTELLHEBEL
54	25510000/0	1	PERNO	PIN	PIVOT	BOLZEN
55	25430202/0	1	MOLLA	SPRING	RESSORT	FEDER
56	12604897/0	2	RONDELLA	WASHER	RONDELLE	SCHEIBE
57	25722450/0	1	SEDILE (TC - TCR)	SEAT (TC - TCR)	SIEGE (TC - TCR)	SITZ (TC - TCR)
	25722451/1	1	SEDILE (TCP)	SEAT (TCP)	SIEGE (TCP)	SITZ (TCP)
58	12793101/0	4	VITE	SCREW	VIS	SCHRAUBE
59	12583500/0	4	GROWER	GROWER	GROWER	GROWER
60	25430205/0	2	MOLLA	SPRING	RESSORT	FEDER
61	25510016/0	2	PERNO	PIN	PIVOT	BOLZEN
62	12521350/0	2	RONDELLA	WASHER	RONDELLE	SCHEIBE
63	12583500/0	2	GROWER	GROWER	GROWER	GROWER
64	12523070/0	2	RONDELLA	WASHER	RONDELLE	SCHEIBE
65	25122000/1	2	CUFFIA PROTEZIONE	HOOD	PROTECTEUR	SCHUTZKASTEN
66	25430223/0	1	MOLLA	SPRING	RESSORT	FEDER

TC102

TCP102

TCR102

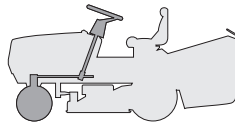

**STERZO
STEERING
BARRE DE DIRECTION
LENKGETRIEBE**

2000

003.0

1 / 2

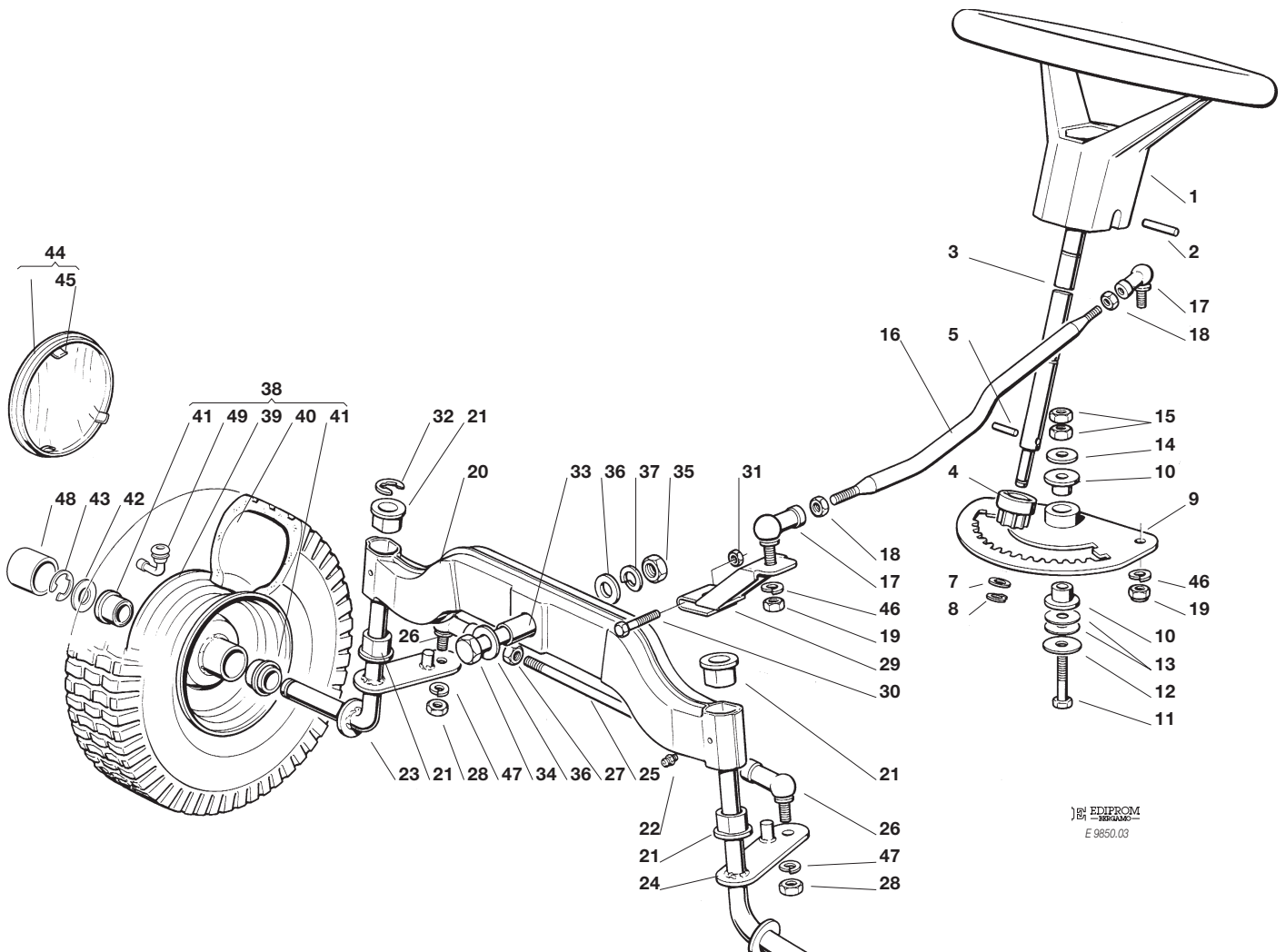

EDIPROM
E 9850.03

N.	CODE	Q.TY	DESCRIZIONE	DESCRIPTION	DESCRIPTION	BESCHREIBUNG
1	25961200/0	1	VOLANTE	STEERING WHEEL	VOLANT	LENKRAD
2	12620299/0	1	SPINA	PIN	GOUPILLE	STIFT
3	25520002/1	1	PIANTONE	STEERING COLUMN	TUBE DE DIRECTION	LENKUNGSAEULE
4	25570000/0	1	PIGNONE	PINION	PIGNON	RITZEL
5	12622650/0	1	SPINA	PIN	GOUPILLE	STIFT
7	12521370/0	1	RONDELLA	WASHER	RONDELLE	SCHEIBE
8	12436030/0	1	PIASTRINA	PLATE	PLAQUETTE	PLATTECHEN
9	82735504/0	1	SETTORE STERZO	STEERING SHAFT	ARBRE DIRECTION	LENKUNGSWELLE
10	25160001/1	2	BRONZINA	BRASS	COUSSINET	BÜCHSE
11	12692420/0	1	VITE	SCREW	VIS	SCHRAUBE
12	12523090/0	1	RONDELLA	WASHER	RONDELLE	SCHEIBE
13	22672150/0	2	RONDELLA	WASHER	RONDELLE	SCHEIBE
14	25670002/0	1	RONDELLA	WASHER	RONDELLE	SCHEIBE
15	12295200/0	2	DADO	NUT	ECROU	MUTTER
16	25033003/1	1	ASTA COMANDO STERZO	STEERING ROD	LEVIER BARRE DE DIRECTION	LENKUNGSSTAB
17	22746600/0	2	SNODO M10	JOINT M10	JOINT M10	GELENK M10
18	12295200/0	2	DADO	NUT	ECROU	MUTTER
19	12295200/0	2	DADO	NUT	ECROU	MUTTER
20	82034001/2	1	BILANCIERE COMPLETO DI BRONZINA ED INGRASSATORE	EQUALIZER WITH BUSH AND LUBRICATOR	BALANCIER AVEC COUSSINET ET GRAISSEUR	KIPPHEBEL MIT BRONZE- LAGER UND FETTBÜCHSE
21	25034002/1	4	BRONZINA	BRASS	COUSSINET	BÜCHSE
22	12379511/0	2	INGRASSATORE	GREASE DISPENSER	GRAISSEUR	FETTBÜCHSE
23	82230349/0	1	FUSELLO DX	R. STUB AXLE	FUSEAU DROITE	RECHTER ACHSSCHENKEL
24	82230348/0	1	FUSELLO SX	L. STUB AXLE	FUSEAU GAUCHE	LINKER ACHSSCHENKEL
25	25840001/0	1	TIRANTE	TIE ROD	TIRANT	KUPPLUNG
26	22746600/0	2	SNODO M10	JOINT M10	JOINT M10	GELENK M10
27	12295200/0	2	DADO	NUT	ECROU	MUTTER
28	12295200/0	2	DADO	NUT	ECROU	MUTTER
29	82318101/0	1	ASS. LEVA COMANDO	LEVER ASS.Y	ENSEMBLE LEVIER	HEBEL



N.	CODE	Q.TY	DESCRIZIONE	DESCRIPTION	DESCRIPTION	BESCHREIBUNG
30	12691700/0	1	VITE	SCREW	VIS	SCHRAUBE
31	12155000/0	1	DADO	NUT	ECROU	MUTTER
32	12001000/0	1	ANELLO ELASTICO	SNAP RING	ANNEAU RESSORT	SPRENGRING
33	25160005/0	1	DISTANZIALE	SPACER	ENTRETOISE	ENTFERNUNGSSTUECK
34	12694100/0	1	VITE	SCREW	VIS	SCHRAUBE
35	12295800/0	1	DADO	NUT	ECROU	MUTTER
36	12521390/0	2	RONDELLA	WASHER	RONDELLE	SCHEIBE
37	12587900/0	1	GROWER	GROWER	GROWER	GROWER
38	☛	2	RUOTA ANTERIORE	FRONT WHEEL	ROUE AVANT	VORDERRAD
	82680002/1		TURF SAVER CARLISLE	TURF SAVER CARLISLE	TURF SAVER CARLISLE	TURF SAVER CARLISLE
	82680005/1		DELI TIRE	DELI TIRE	DELI TIRE	DELI TIRE
39	82000590/0	2	CERCHIO RUOTA	RIMM	BANDAGE ROUE	VORDERRAD FELGER
40	☛	2	PNEUMATICO	SHOE	PNEU	REIFEN
	25590000/0		TURF SAVER CARLISLE	TURF SAVER CARLISLE	TURF SAVER CARLISLE	TURF SAVER CARLISLE
	25590002/0		DELI TIRE	DELI TIRE	DELI TIRE	DELI TIRE
41	25122200/1	4	CUSCINETTO	BEARING	ROULEMENT	LAGER
42	25670005/1	2	RONDELLA	WASHER	RONDELLE	SCHEIBE
			SPESSORE 2,5 MM	THICKNEE 2.5 MM	EPAISSEUR 2,5 MM	DICKE 2,5 MM
43	12001000/0	2	ANELLO ELASTICO	SNAP RING	ANNEAU RESSORT	SPRENGRING
44	82110250/1	2	ASS. COPRIDISCO RUOTA ANTERIORE (TC - TCR)	FRONT WHEEL COVERENS. ASS.Y (TC - TCR)	COUVRE DISQUE ROUE ANTER. (TC - TCR)	VORRDERRAD DECKEL (TC - TCR)
	82110252/0	2	ASS. COPRIDISCO RUOTA ANTERIORE (TCP)	FRONT WHEEL COVERENS. ASS.Y (TCP)	COUVRE DISQUE ROUE ANTERIEURE (TCP)	VORRDERRAD DECKEL (TCP)
45	25430209/0	8	MOLLA AGGANCIO	SPRING	RESSORT	FEDER
46	12585100/0	2	GROWER	GROWER	GROWER	GROWER
47	12585100/0	2	GROWER	GROWER	GROWER	GROWER
48	22110230/0	2	COPRIMOZZO	HUB COVER	COUVRE MOYEU	RADNABE DECKEL
49	25950002/0	2	VALVOLA	VALVE	SOUPAPE	VENTIL

TC102

TCP102

TCR102



COMANDO FRENO E COMANDO CAMBIO
BRAKE AND GEARBOX CONTROLS
COMMANDE FREIN ET BOITE DE VITESSE
BREMSE UND WECHSEL ANTRIEB

2000

004.0

1 / 2

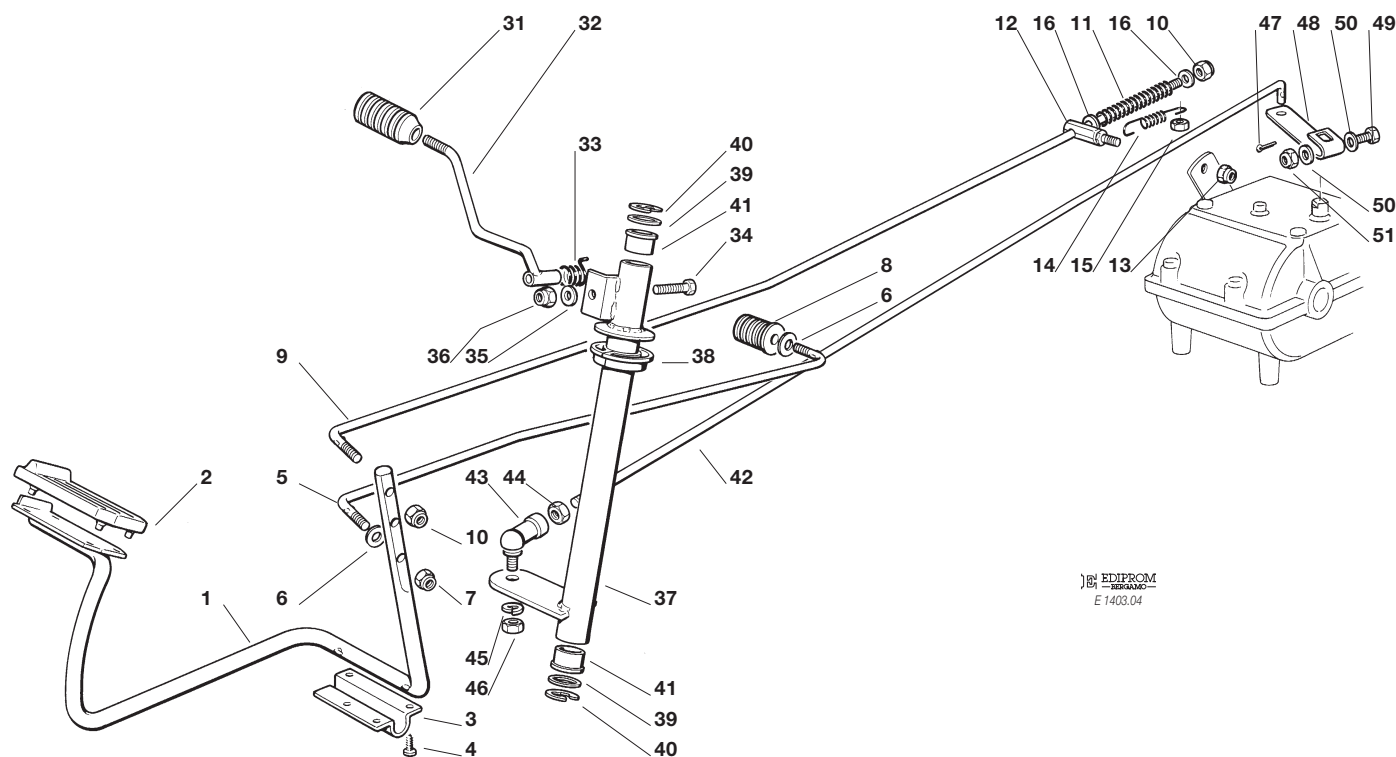

EDIPROM
E 1403.04

N.	CODE	Q.TY	DESCRIZIONE	DESCRIPTION	DESCRIPTION	BESCHREIBUNG
1	82500001/0	1	PEDALE FRENO	BRAKE PEDAL	PEDALE DE FREIN	BREMSPEDAL
2	25110269/0	1	COPRISTAFFA	CLAMP COVER	COUVRE ETRIER	BRIDEDECKEL
3	25547012/1	1	PIASTRINA	PLATE	PLAQUE	PLATTE
4	12731601/0	4	VITE	SCREW	VIS	SCHRAUBE
5	25033005/0	1	ASTA	ROD	BARRE	STANGE
6	12523060/0	2	RONDELLA	WASHER	RONDELLE	SCHEIBE
7	12155000/0	1	DADO	NUT	ECROU	MUTTER
8	25394500/1	1	MANOPOLA FRENO	BRAKE KNOB	POIGNEE DE FREIN	BREMSEKNOPF
9	25033007/0	1	ASTA COMANDO FRENO	BRAKE CONTROL ROD	TIGE CONTROLE FREIN	BREMSE KONTROLLESATZ
10	12154510/0	2	DADO	NUT	ECROU	MUTTER
11	25430212/1	1	MOLLA	SPRING	RESSORT	FEDER
12	25510017/0	1	PERNO	PIN	PIVOT	BOLZEN
13	12155000/0	1	DADO	NUT	ECROU	MUTTER
14	25430213/0	1	MOLLA RICHIAMO FRENO	SPRING BRAKE	RESSORT FREIN	FEDER BREMSE
15	12155000/0	1	DADO	NUT	ECROU	MUTTER
16	12521330/0	2	RONDELLA	WASHER	RONDELLE	SCHEIBE
31	25394505/1	1	MANOPOLA CAMBIO	GEARBOX KNOB	POIGNEE BOITE DE VITESSE	WECHSELGETRIEBE
32	82318130/0	1	LEVA COMANDO CAMBIO	GEARSHIFT	LEVIER CHANGEMENT VITESSE	DEGETRIEBE HEBEL
33	25430225/0	1	MOLLA	SPRING	RESSORT	FEDER
34	12689515/0	1	VITE	SCREW	VIS	SCHRAUBE
35	12521330/0	1	RONDELLA	WASHER	RONDELLE	SCHEIBE
36	12154510/0	1	DADO	NUT	ECROU	MUTTER
37	82869005/0	1	TUBO COMANDO	SPEED DRIVE TUBE	TUBE COMMANDE CHANGE- MENT DE VITESSE	GAENGESCHALTUNG ROHR
38	25040602/0	2	BUSSOLA	BUSH	DOUILLE	BÜCHSE
39	25670006/0	2	RONDELLA	WASHER	RONDELLE	SCHEIBE
40	12001000/0	2	SEEGER	SEEGER	SEEGER	SEEGER
41	25040601/0	2	BUSSOLA	BUSH	DOUILLE	BÜCHSE



N.	CODE	Q.TY	DESCRIZIONE	DESCRIPTION	DESCRIPTION	BESCHREIBUNG
42	25033004/0	1	ASTA	ROD	BARRE	STANGE
43	22746601/0	1	SNODO M8	JOINT M8	JOINT M8	GELENK M8
44	12293200/0	1	DADO	NUT	ECROU	MUTTER
45	12583500/0	1	GROWER	GROWER	GROWER	GROWER
46	12293200/0	1	DADO	NUT	ECROU	MUTTER
47	12141418/0	1	COPPIGLIA	COTTER PIN	GOUPILLE	SPLIT
48	25318117/0	1	LEVA CAMBIO	GEARSHIFT	LEVIER CHANGEMENT DE VITESSE	GETRIEBE HEBEL
49	12689500/0	1	VITE	SCREW	VIS	SCHRAUBE
50	12521330/0	2	RONDELLA	WASHER	RONDELLE	SCHEIBE
51	12154510/0	1	DADO	NUT	ECROU	MUTTER

TC102

TCP102

TCR102

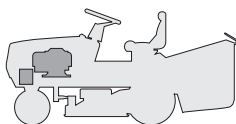

MOTORE
ENGINE
MOTEUR
MOTOR
 12 - 12,5 - 13 HP B&S

2000

005.0

1 / 1

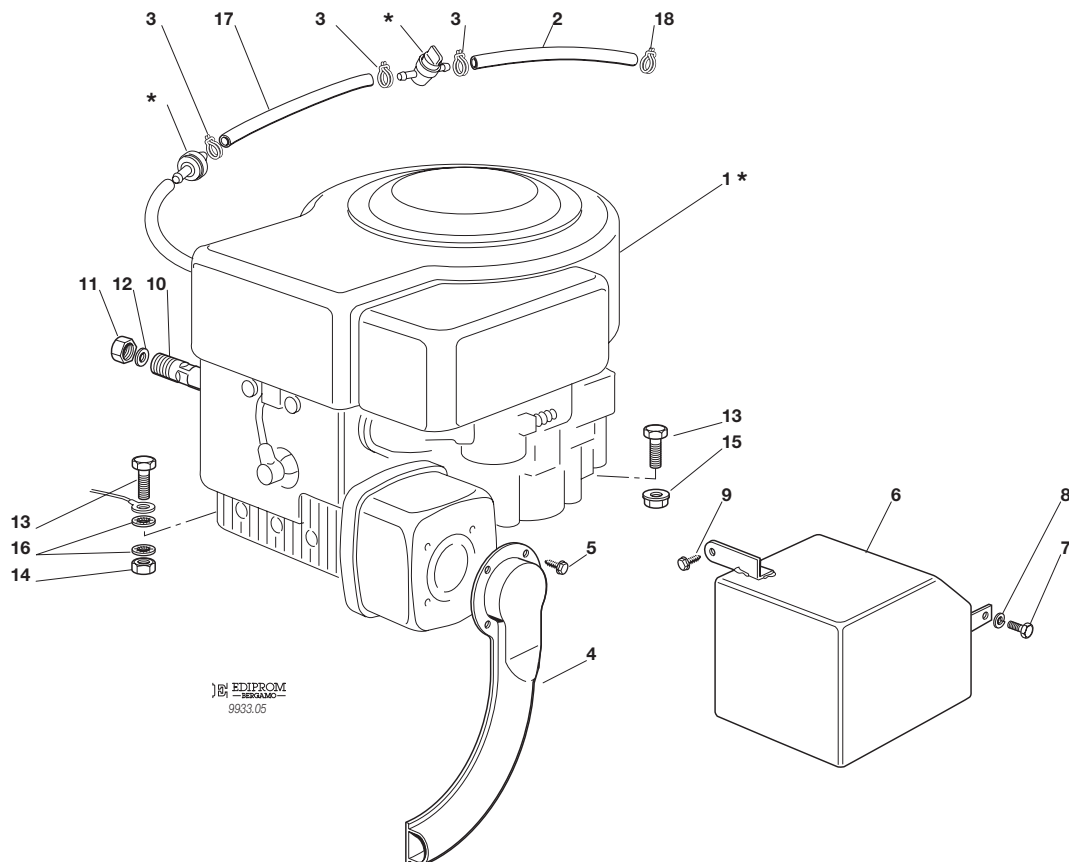

EDIPROM
 9933.05

N.	CODE	Q.TY	DESCRIZIONE	DESCRIPTION	DESCRIPTION	BESCHREIBUNG
1★	—	1	MOTORE	ENGINE	MOTEUR	MOTOR
2	25869016/0	1	TUBO COLLEGAMENTO	CONNECTING TUBE	TUBE DE CONNEXION	VERBINDUNGSROHR
3	18375051/1	3	FASCETTA	FAIR LED	FIXATION DE CABLE	KABELBEFESTIGUNG
4	82640001/1	1	RACCORDO SCARICO	EXHAUST CONNECTION	CONNEXION ECHAPPEMENT	AUSPUFFANSCHLUSS
5	12735106/0	4	VITE	SCREW	VIS	SCHRAUBE
6	82598001/0	1	PROTEZIONE SILENZIATORE	MUFFLER PROTECTION	PROTECTION SILENCIEUX	AUSPUFFSCHUTZ
7	12735510/0	1	VITE	SCREW	VIS	SCHRAUBE
8	12540260/0	1	RONDELLA	WASHER	RONDELLE	SCHIBE
9	12735104/0	1	VITE	SCREW	VIS	SCHRAUBE
10	25598050/0	1	PROLUNGA SCARICO OLIO	OIL DISCHARGE EXTENSION	EXTENSION RALLONGE DE DECH. HUILE	ÖL ENTLEERUNGSVERLAEN- GERUNG
11	18737849/0	1	TAPPO PER PROLUNGA	OIL CAP	BOUCHON HUILE	OELVERSCHLUSS
12	18401001/0	1	GUARNIZIONE	OIL SEAL	GARNITURE	DICHTUNG
13	12691115/0	4	VITE	SCREW	VIS	SCHRAUBE
14	12293200/0	1	DADO	NUT	ECROU	MUTTER
15	12293201/0	3	DADO	NUT	ECROU	MUTTER
16	12540260/0	2	RONDELLA	WASHER	RONDELLE	SCHIBE
17	25869006/0	1	TUBO COLLEGAMENTO	CONNECTING TUBE	TUBE DE CONNEXION	VERBINDUNGSROHR
18	18375053/0	1	FASCETTA	FAIR LED	FIXATION DE CABLE	KABELBEFESTIGUNG

PER LA SOSTITUZIONE DELLE PARTI CONTRASSEGNALE CON «★» RIVOLGERSI AL SERVIZIO ASSISTENZA DEL COSTRUTTORE DEL MOTORE.
 TO REPLACE THE PARTS MARKED «★» SEEK ASSISTANCE FROM THE ENGINE MANUFACTURER'S AFTER SALES SERVICE.
 POUR LE REMPLACEMENT DES PIÈCES MARQUÉES AVEC «★» S'ADRESSER AU SERVICE APRÈS VENTES DU CONSTRUCTEUR DU MOTEUR.
 ZUM AUSTAUSCH DER MIT «★» GEKENNZEICHNETEN TEILE, WENDEN SIE SICH AN DEN KUNDENDIENST DES HERSTELLERS DES MOTOR.

TC102

TCP102

TCR102

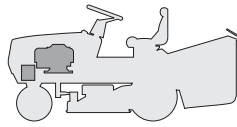

MOTORE
ENGINE
MOTEUR
MOTOR
18 HP B&S

2000

005a.0

1 / 2

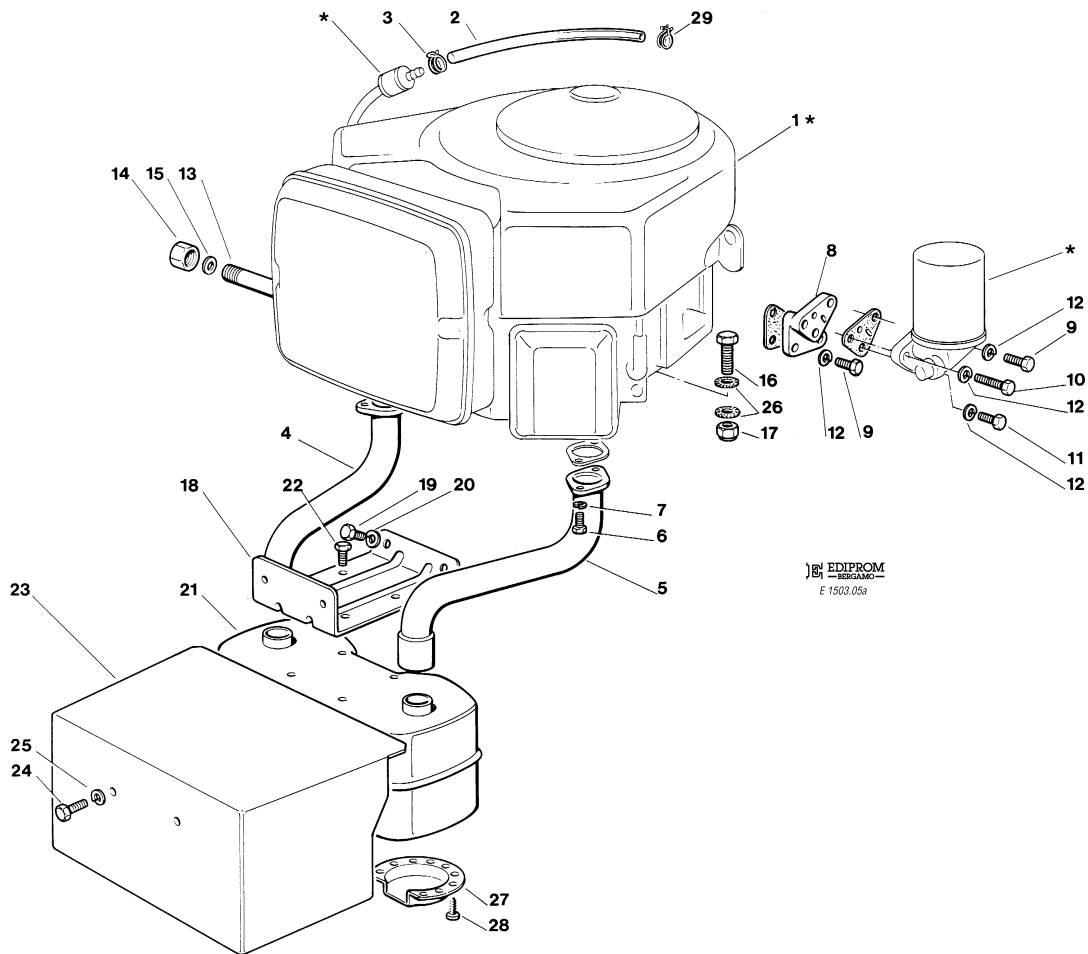

EDIPROM
E 1503.05a

N.	CODE	Q.TY	DESCRIZIONE	DESCRIPTION	DESCRIPTION	BESCHREIBUNG
1★	—	1	MOTORE	ENGINE	MOTEUR	MOTOR
2	25869017/0	1	TUBO COLLEGAMENTO	CONNECTING TUBE	TUBE DE CONNEXION	VERBINDUNGSROHR
3	18375051/1	1	FASCETTA	FAIR LED	FIXATION DE CABLE	KABELBEFESTIGUNG
4	18738202/0	1	TUBO RACCORDO SCARICO DX	EXHAUST RIGHT CONNECTING TUBE	TUBE DE CONNEXION DROIT POUR ECHAPP.	RECHTES VERBINDUNGS- ROHR FÜR ABGASUNG
5	18738203/0	1	TUBO RACCORDO SCARICO SX	EXHAUST LEFT CONNECTING TUBE	TUBE DE CONNEXION GAUCHE POUR ECHAPP.	LINKES VERBINDUNGS- ROHR FÜR ABGASUNG
6	12793101/0	4	VITE	SCREW	VIS	SCHRAUBE
7	12583500/0	4	GROWER	GROWER	GROWER	GROWER
8	25785095/0	1	SUPPORTO FILTRO	FILTER SUPPORT	SUPPORTE DU FILTRE	WECHSELFILTER HALTER
9	12791400/0	3	VITE	SCREW	VIS	SCHRAUBE
10	12689515/0	1	VITE	SCREW	VIS	SCHRAUBE
11	12791213/0	1	VITE	SCREW	VIS	SCHRAUBE
12	12582100/0	5	GROWER	GROWER	GROWER	GROWER
13	25598050/0	1	PROLUNGA SCARICO OLIO	OIL DISCHARGE EXTENSION	EXTENSION RALLONGE DE DECH. HUILE	ÖL ENTLEERUNGSVERLAEN- GERUNG
14	18737849/0	1	TAPPO PROLUNGA	OIL CAP	BOUCHON HUILE	OELVERSCHLUSS
15	18401001/0	1	GUARNIZIONE	OIL SEAL	GARNITURE	DICHTUNG
16	12691115/0	4	VITE	SCREW	VIS	SCHRAUBE
17	12293201/0	3	DADO	NUT	ECROU	MUTTER
	12293200/0	1	DADO	NUT	ECROU	MUTTER
18	82785093/0	1	SUPPORTO SILENZIATORE	MUFFLER SUPPORT	SUPPORT SILENCIEUX	AUSPUFFHALTERSATZ
19	12793102/0	2	VITE	SCREW	VIS	SCHRAUBE
20	12583500/0	2	GROWER	GROWER	GROWER	GROWER
21	18716131/1	1	SILENZIATORE COMPLETO DI DEFLETTORE	MUFFLER WITH DEFLECTOR	SILENCEUX AVEC DEFLECTEUR	AUSPUFF MIT DEFLEKTOR
22	12735599/0	4	VITE	SCREW	VIS	SCHRAUBE
23	82598005/1	1	PROTEZIONE	GUARD	PROTECTION	SCHUTZE
24	12792610/0	2	VITE	SCREW	VIS	SCHRAUBE
25	12583500/0	2	GROWER	GROWER	GROWER	GROWER
26	12540260/0	2	RONDELLA	WASHER	RONDELLE	SCHEIBE





N.	CODE	Q.TY	DESCRIZIONE	DESCRIPTION	DESCRIPTION	BESCHREIBUNG
27	18310005/0	1	DEFLETTORE	DEFLECTOR	DEFLECTEUR	DEFLEKTOR
28	12735106/0	4	VITE	SCREW	VIS	SCHRAUBE
29	18375053/0	1	FASCETTA	FAIR LED	FIXATION DE CABLE	KABELBEFESTIGUNG

PER LA SOSTITUZIONE DELLE PARTI CONTRASSEGNAE CON «*» RIVOLGERSI AL SERVIZIO ASSISTENZA DEL COSTRUTTORE DEL MOTORE.
TO REPLACE THE PARTS MARKED «*» SEEK ASSISTANCE FROM THE ENGINE MANUFACTURER'S AFTER SALES SERVICE.
POUR LE REMPLACEMENT DES PIÈCES MARQUÉES AVEC «*» S'ADRESSER AU SERVICE APRÈS VENTES DU CONSTRUCTEUR DU MOTEUR.
ZUM AUSTAUSCH DER MIT «*» GEKENNZEICHNETEN TEILE, WENDEN SIE SICH AN DEN KUNDENDIENST DES HERSTELLERS DES MOTOR.

TC102

TCP102

TCR102

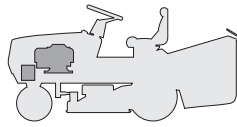

**MOTORE
ENGINE
MOTEUR
MOTOR**
15,5 HP B&S

2000

005b.0

1 / 1

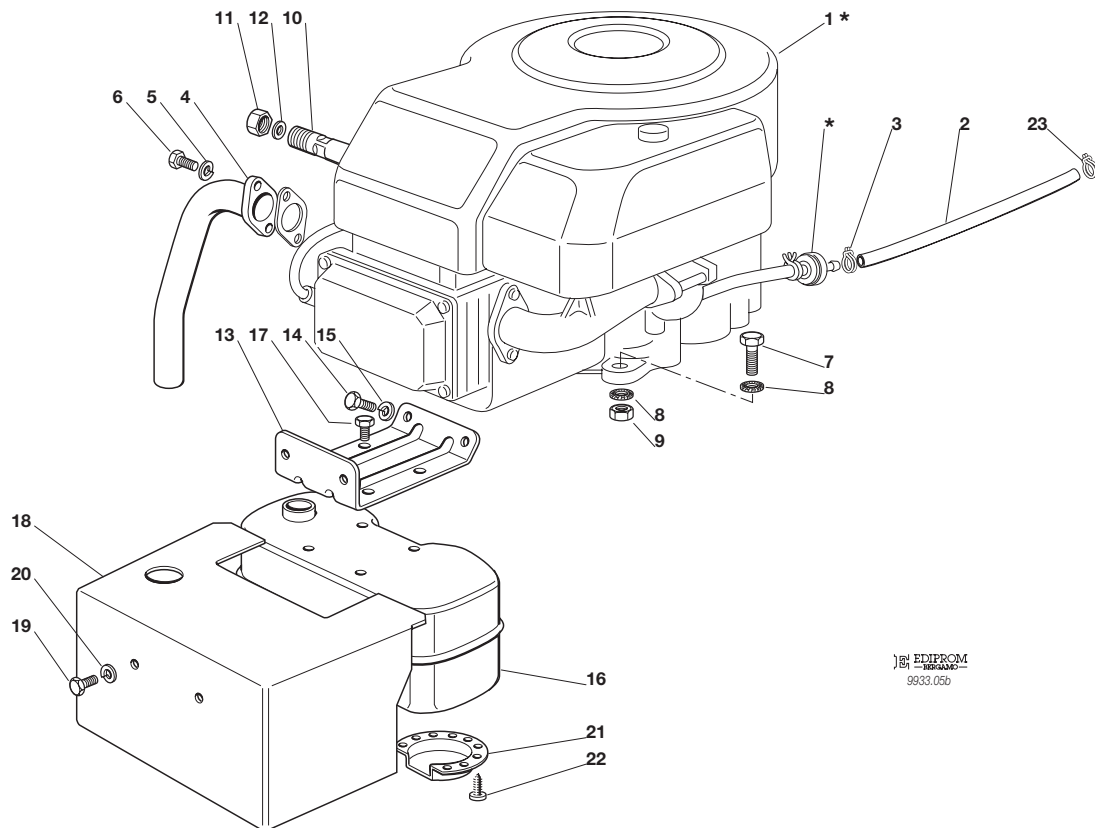

EDIPROM
9933.05b

N.	CODE	Q.TY	DESCRIZIONE	DESCRIPTION	DESCRIPTION	BESCHREIBUNG
1★	—	1	MOTORE	ENGINE	MOTEUR	MOTOR
2	25869016/0	1	TUBO COLLEGAMENTO	CONNECTING TUBE	TUBE DE CONNEXION	VERBINDUNGSROHR
3	18375051/1	1	FASCETTA	FAIR LED	FIXATION DE CABLE	KABELBEFESTIGUNG
4	18738206/0	1	TUBO RACCORDO SCARICO	EXHAUST CONNECTING TUBE	TUBE DE CONNEXION POUR ECHAPPEMENT	VERBINDUNGSROHR FÜR ABGASUNG
5	12583500/0	2	GROWER	GROWER	GROWER	GROWER
6	12735530/0	2	VITE	SCREW	VIS	SCHRAUBE
7	12691115/0	4	VITE	SCREW	VIS	SCHRAUBE
8	12540260/0	4	GROWER	GROWER	GROWER	GROWER
9	12293200/0	4	DADO	NUT	ECROU	MUTTER
10	25598050/0	1	PROLUNGA SCARICO OLIO	OIL DISCHARGE EXTENSION	EXTENSION RALLONGE DE DECH. HUILE	ÖL ENTLERUNGSVERLAEN- GERUNG
11	18737849/0	1	TAPPO PROLUNGA	OIL CAP	BOUCHON HUILE	OELVERSCHLUSS
12	18401001/0	1	GUARNIZIONE	OIL SEAL	GARNITURE	DICHTUNG
13	82785093/0	1	SUPPORTO SILENZIATORE	MUFFLER SUPPORT	SUPPORT SILENCIEUX	AUSPUFFHALTERSATZ
14	12793102/0	1	VITE	SCREW	VIS	SCHRAUBE
15	12583500/0	2	GROWER	GROWER	GROWER	GROWER
16	18716132/0	1	SILENZIATORE COMPLETO DI DEFLETTORE	MUFFLER WITH DEFLECTOR	SILENCEUX AVEC DEFLECTEUR	AUSPUFF MIT DEFLEKTOR
17	12735599/0	4	VITE	SCREW	VIS	SCHRAUBE
18	82598009/1	1	PROTEZIONE	GUARD	PROTECTION	SCHUTZE
19	12792611/0	2	VITE	SCREW	VIS	SCHRAUBE
20	12583500/0	2	GROWER	GROWER	GROWER	GROWER
21	18310005/0	1	DEFLETTORE	DEFLECTOR	DEFLECTEUR	DEFLEKTOR
22	12735106/0	4	VITE	SCREW	VIS	SCHRAUBE
23	18375053/0	1	FASCETTA	FAIR LED	FIXATION DE CABLE	KABELBEFESTIGUNG

PER LA SOSTITUZIONE DELLE PARTI CONTRASSEGNALE CON «★» RIVOLGERSI AL SERVIZIO ASSISTENZA DEL COSTRUTTORE DEL MOTORE.
TO REPLACE THE PARTS MARKED «★» SEEK ASSISTANCE FROM THE ENGINE MANUFACTURER'S AFTER SALES SERVICE.
POUR LE REMPLACEMENT DES PIÈCES MARQUÉES AVEC «★» S'ADRESSER AU SERVICE APRÈS VENTES DU CONSTRUCTEUR DU MOTEUR.
ZUM AUSTAUSCH DER MIT «★» GEKENNZEICHNETEN TEILE, WENDEN SIE SICH AN DEN KUNDENDIENST DES HERSTELLERS DES MOTOR.

TC102

TCP102

TCR102

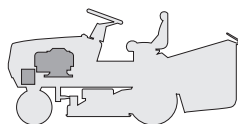

**MOTORE
ENGINE
MOTEUR
MOTOR
13 HP TECUMSEH**

2000

005c.0

1 / 2

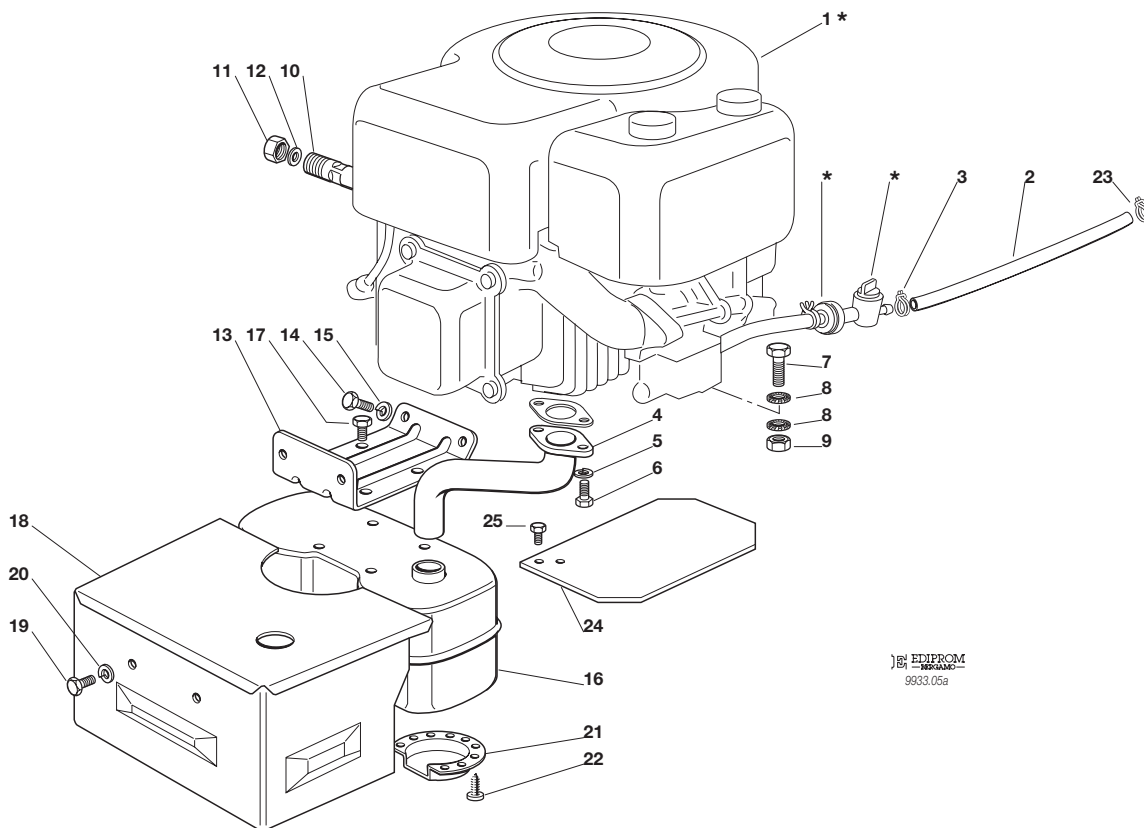

EDIPROM
9933.05a

N.	CODE	Q.TY	DESCRIZIONE	DESCRIPTION	DESCRIPTION	BESCHREIBUNG
1★	—	1	MOTORE	ENGINE	MOTEUR	MOTOR
2	25869027/0	1	TUBO COLLEGAMENTO	CONNECTING TUBE	TUBE DE CONNEXION	VERBINDUNGSROHR
3	18375051/1	1	FASCETTA	FAIR LED	FIXATION DE CABLE	KABELBEFESTIGUNG
4	18738211/0	1	TUBO RACCORDO SCARICO	EXHAUST CONNECTING TUBE	TUBE DE CONNEXION POUR ECHAPPEMENT	VERBINDUNGSROHR FÜR ABGASUNG
5	12583500/0	2	GROWER	GROWER	GROWER	GROWER
6	12735530/0	2	VITE	SCREW	VIS	SCHRAUBE
7	12691100/0	4	VITE	SCREW	VIS	SCHRAUBE
8	12540260/0	4	RONDELLA	WASHER	RONDELLE	SCHEIBE
9	12293200/0	1	DADO	NUT	ECROU	MUTTER
10	25598050/0	1	PROLUNGA SCARICO OLIO	OIL DISCHARGE EXTENSION	EXTENSION RALLONGE DE DECH. HUILE	ÖL ENTLEERUNGSVERLAEN- GERUNG
11	18737849/0	1	TAPPO PROLUNGA	OIL CAP	BOUCHON HUILE	OELVERSCHLUSS
12	18401001/0	1	GUARNIZIONE	OIL SEAL	GARNITURE	DICHTUNG
13	82785093/0	1	SUPPORTO SILENZIATORE	MUFFLER SUPPORT	SUPPORT SILENCIEUX	AUSPUFFHALTERSATZ
14	12793102/0	2	VITE	SCREW	VIS	SCHRAUBE
15	12583500/0	2	GROWER	GROWER	GROWER	GROWER
16	18716132/0	1	SILENZIATORE COMPLETO DI DEFLETTORE	MUFFLER WITH DEFLECTOR	SILENCIEUX AVEC DEFLECTEUR	AUSPUFF MIT DEFLEKTOR
17	12735599/0	4	VITE	SCREW	VIS	SCHRAUBE
18	82598017/0	1	PROTEZIONE	GUARD	PROTECTION	SCHUTZE
19	12792611/0	2	VITE	SCREW	VIS	SCHRAUBE
20	12583500/0	2	GROWER	GROWER	GROWER	GROWER
21	18310005/0	1	DEFLETTORE	DEFLECTOR	DEFLECTEUR	DEFLEKTOR
22	12735106/0	4	VITE	SCREW	VIS	SCHRAUBE
23	18375053/0	1	FASCETTA	FAIR LED	FIXATION DE CABLE	KABELBEFESTIGUNG
24	25600031/0	1	PROTEZIONE SILENZIATORE	MUFFLER PROTECTION	PROTECTION SILENCIEUX	AUSPUFFSCHUTZ
25	12735106/0	2	VITE	SCREW	VIS	SCHRAUBE



N.	CODE	Q.TY	DESCRIZIONE	DESCRIPTION	DESCRIPTION	BESCHREIBUNG
----	------	------	-------------	-------------	-------------	--------------

PER LA SOSTITUZIONE DELLE PARTI CONTRASSEGNAE CON «★» RIVOLGERSI AL SERVIZIO ASSISTENZA DEL COSTRUTTORE DEL MOTORE.
TO REPLACE THE PARTS MARKED «★» SEEK ASSISTANCE FROM THE ENGINE MANUFACTURER'S AFTER SALES SERVICE.
POUR LE REMPLACEMENT DES PIÈCES MARQUÉES AVEC «★» S'ADRESSER AU SERVICE APRÈS VENTES DU CONSTRUCTEUR DU MOTEUR.
ZUM AUSTAUSCH DER MIT «★» GEKENNZEICHNETEN TEILE, WENDEN SIE SICH AN DEN KUNDENDIENST DES HERSTELLERS DES MOTOR.

TC102

TCP102

TCR102

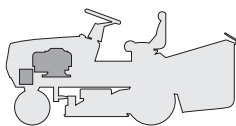

MOTORE
ENGINE
MOTEUR
MOTOR
15 HP TECUMSEH

2000

005d.0

1 / 2

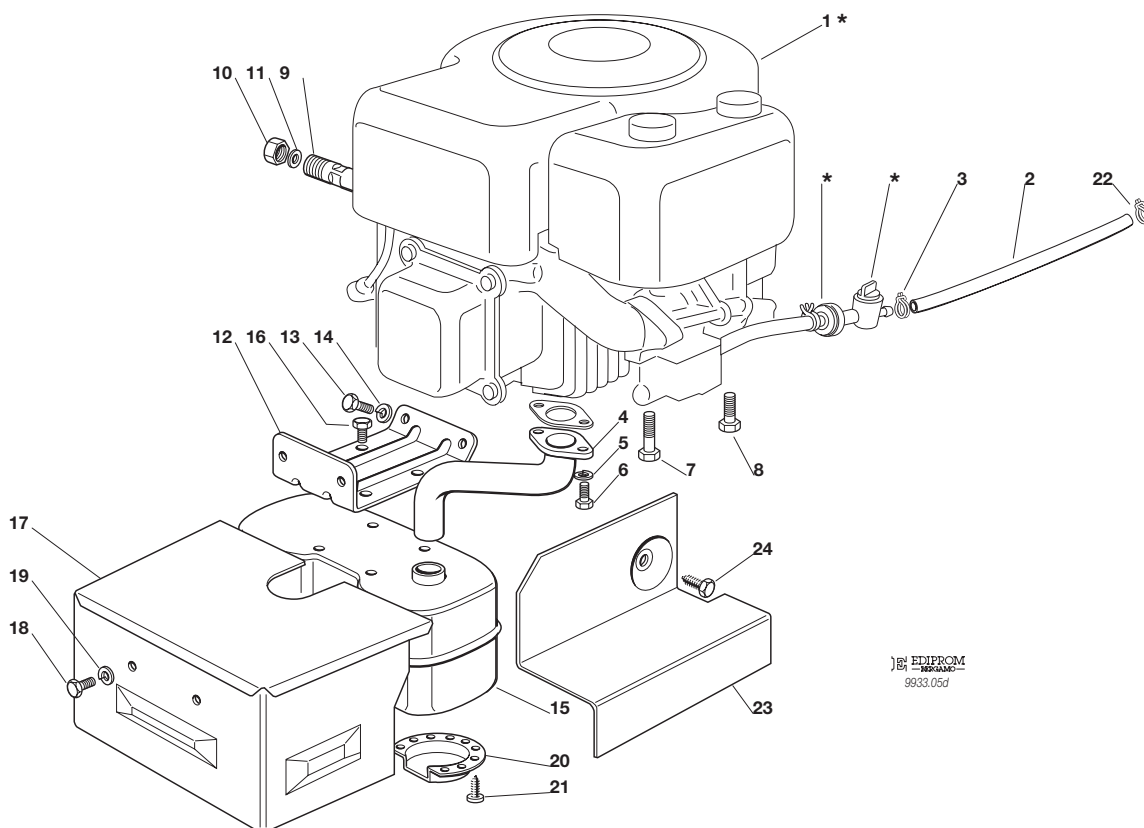

EDIPROM
9933.05d

N.	CODE	Q.TY	DESCRIZIONE	DESCRIPTION	DESCRIPTION	BESCHREIBUNG
1★	—	1	MOTORE	ENGINE	MOTEUR	MOTOR
2	25869027/0	1	TUBO COLLEGAMENTO	CONNECTING TUBE	TUBE DE CONNEXION	VERBINDUNGSROHR
3	18375051/1	1	FASCETTA	FAIR LED	FIXATION DE CABLE	KABELBEFESTIGUNG
4	18738212/0	1	TUBO RACCORDO SCARICO	EXHAUST CONNECTING TUBE	TUBE DE CONNEXION POUR ECHAPPEMENT	VERBINDUNGSROHR FÜR ABGASUNG
5	12583500/0	2	GROWER	GROWER	GROWER	GROWER
6	12735530/0	2	VITE	SCREW	VIS	SCHRAUBE
7	12735109/0	3	VITE	SCREW	VIS	SCHRAUBE
8	12735108/0	1	VITE	SCREW	VIS	SCHRAUBE
9	25598050/0	1	PROLUNGA SCARICO OLIO	OIL DISCHARGE EXTENSION	EXTENSION RALLONGE DE DECH. HUILE	ÖL ENTLEERUNGSVERLAEN- GERUNG
10	18737849/0	1	TAPPO PROLUNGA	OIL CAP	BOUCHON HUILE	OELVERSCHLUSS
11	18401001/0	1	GUARNIZIONE	OIL SEAL	GARNITURE	DICHTUNG
12	82785093/0	1	SUPPORTO SILENZIATORE	MUFFLER SUPPORT	SUPPORT SILENCIEUX	AUSPUFFHALTERSATZ
13	12793102/0	2	VITE	SCREW	VIS	SCHRAUBE
14	12583500/0	2	GROWER	GROWER	GROWER	GROWER
15	18716132/0	1	SILENZIATORE COMPLETO DI DEFLETTORE	MUFFLER WITH DEFLECTOR	SILENCIEUX AVEC DEFLECTEUR	AUSPUFF MIT DEFLEKTOR
16	12735599/0	4	VITE	SCREW	VIS	SCHRAUBE
17	82598019/0	1	PROTEZIONE	GUARD	PROTECTION	SCHUTZE
18	12792611/0	2	VITE	SCREW	VIS	SCHRAUBE
19	12583500/0	2	GROWER	GROWER	GROWER	GROWER
20	18310005/0	1	DEFLETTORE	DEFLECTOR	DEFLECTEUR	DEFLEKTOR
21	12735106/0	4	VITE	SCREW	VIS	SCHRAUBE
22	18375053/0	1	FASCETTA	FAIR LED	FIXATION DE CABLE	KABELBEFESTIGUNG
23	25600038/0	1	PROTEZIONE SILENZIATORE	MUFFLER PROTECTION	PROTECTION SILENCIEUX	AUSPUFFSCHUTZ
24	12734995/0	1	VITE	SCREW	VIS	SCHRAUBE

PER LA SOSTITUZIONE DELLE PARTI CONTRASSEGNALE CON «★» RIVOLGERSI AL SERVIZIO ASSISTENZA DEL COSTRUTTORE DEL MOTORE.
TO REPLACE THE PARTS MARKED «★» SEEK ASSISTANCE FROM THE ENGINE MANUFACTURER'S AFTER SALES SERVICE.



N.	CODE	Q.TY	DESCRIZIONE	DESCRIPTION	DESCRIPTION	BESCHREIBUNG
----	------	------	-------------	-------------	-------------	--------------

POUR LE REMPLACEMENT DES PIÈCES MARQUÉES AVEC «★» S'ADRESSER AU SERVICE APRÈS VENTES DU CONSTRUCTEUR DU MOTEUR.
ZUM AUSTAUSCH DER MIT «★» GEKENNZEICHNETEN TEILE, WENDEN SIE SICH AN DEN KUNDENDIENST DES HERSTELLERS DES MOTOR.

TC102

TCP102

TCR102

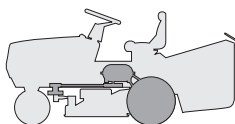

TRASMISSIONE
TRANSMISSION
TRANSMISSION
GETRIEBE

2000

006.0

1 / 2

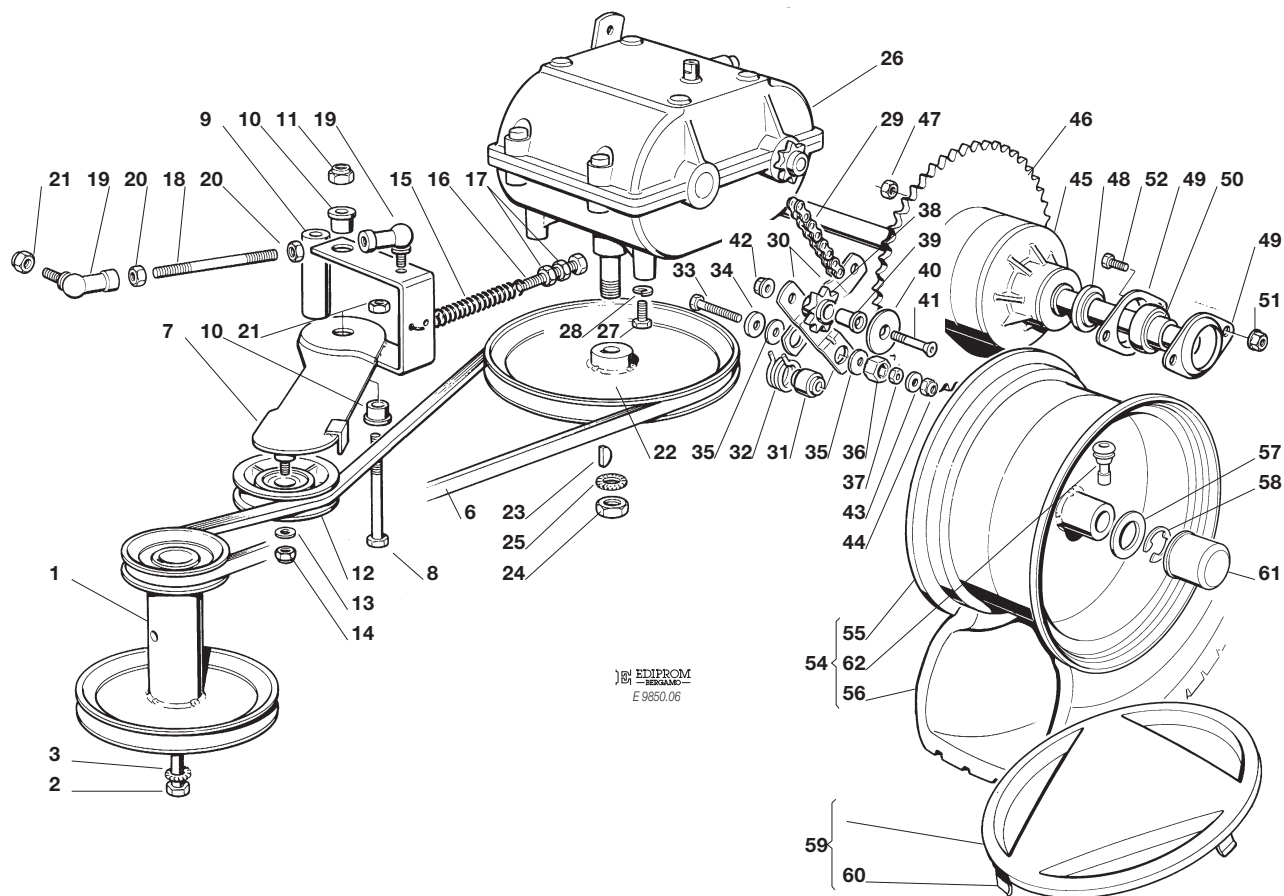

EDIPROM
E 9850.06

N.	CODE	Q.TY	DESCRIZIONE	DESCRIPTION	DESCRIPTION	BESCHREIBUNG
1	25601552/2	1	PULEGGIA MOTORE	ENGINE PULLEY	POULIE MOTEUR	RIEMENSCHLEIBE
2	12737310/0	1	VITE	SCREW	VIS	SCHRAUBE
3	12543000/0	1	RONDELLA	WASHER	RONDELLE	SCHLEIBE
6	35061501/0	1	CINGHIA	BELT	COURROIE	RIEMEN
7	82318111/1	1	LEVA GALOPPINO	TIGHTENER LEVER	LEVIER GALOPIN	LEIT ROLLE
8	12692080/0	1	VITE	SCREW	VIS	SCHRAUBE
9	25160008/0	1	DISTANZIALE	SPACER	ENTRETOISE	ENTFERNUNGSSTUECK
10	25038002/0	2	BOCCOLA	BUSHING	DOUILLE	BÜCHSE
11	12155000/0	1	DADO	NUT	ECROU	MUTTER
12	25601554/0	1	PULEGGIA	PULLEY	POULIE	RIEMENSCHLEIBE
13	12523060/0	1	RONDELLA	WASHER	RONDELLE	SCHLEIBE
14	12155000/0	1	DADO	NUT	ECROU	MUTTER
15	25430219/0	1	MOLLA	SPRING	RESSORT	FEDER
16	22943005/0	1	VITE	SCREW	VIS	SCHRAUBE
17	12293200/0	2	DADO	NUT	ECROU	MUTTER
18	25598002/0	1	PRIGIONIERO	STUD SCREW	PRISONNIER	STIFTSCHLEIBE
19	22746601/0	2	SNODO M8	JOINT M8	JOINT M8	GELENK M8
20	12293200/0	2	DADO	NUT	ECROU	MUTTER
21	12155000/0	2	DADO	NUT	ECROU	MUTTER
22	82601501/0	1	PULEGGIA	PULLEY	POULIE	RIEMENSCHLEIBE
23	12138810/0	1	LINGUETTA	KEY	CLAVETTE	KEIL
24	12361010/0	1	DADO	NUT	ECROU	MUTTER
25	12540280/0	1	RONDELLA	WASHER	RONDELLE	SCHLEIBE
26★	18159002/1	1	CAMBIO	GEAR BOX	BOÎTE DE VITESSE	GETRIEBE
27	12735530/0	4	VITE	SCREW	VIS	SCHRAUBE
28	12583500/0	4	GROWER	GROWER	GROWER	GROWER
29	15189001/0	1	CATENA	CHAIN	CHAINE	KETTE
30	25318122/0	2	LEVA FLOTTANTE	FLOATING LEVER	LEVIER	HEBEL
31	25040607/0	1	BUSSOLA	BUSH	DOUILLE	BÜCHSE
32	25430207/0	1	MOLLA	SPRING	RESSORT	FEDER
33	25943002/0	1	VITE	SCREW	VIS	SCHRAUBE



N.	CODE	Q.TY	DESCRIZIONE	DESCRIPTION	DESCRIPTION	BESCHREIBUNG
34	12523070/0	1	ROSETTA	WASHER	RONDELLE	SCHEIBE
35	22672152/0	2	RONDELLA ANTIFRIZIONE	WASHER	RONDELLE	SCHEIBE
36	25160006/0	1	DISTANZIALE	SPACER	ENTRETOISE	ENTFERNUNGSSTÜCK
37	12293200/0	1	DADO	NUT	ECROU	MUTTER
38	25570001/0	2	PIGNONE	PINION	PIGNON	RITZEL
39	25040608/0	2	BUSSOLA	BUSH	DOUILLE	BUCHSE
40	25670009/0	2	RONDELLA	WASHER	RONDELLE	SCHEIBE
41	12882020/0	2	VITE	SCREW	VIS	SCHRAUBE
42	12155000/0	2	DADO	NUT	ECROU	MUTTER
43	12524010/0	1	ROSETTA	WASHER	RONDELLE	SCHEIBE
44	12155000/0	1	DADO	NUT	ECROU	MUTTER
45★	25140201/0	1	DIFFERENZIALE	DIFFERENTIAL GEAR	DIFFERENTIEL	DIFFERENTIAL
46	16694600/1	1	CORONA	RING GEAR	COURONNE	KRANZ
47	12360354/1	4	DADO	NUT	ECROU	MUTTER
48	25160010/0	2	DISTANZIALE	SPACER	ENTRETOISE	ENTFERNUNGSSTÜCK
49	22207319/0	6	FLANGIA	FLANGE	BRIDE	FLANSCH
50	25122201/0	3	CUSCINETTO	BEARING	COUSSINET	KUGELLAGER
51	12293201/0	4	DADO	NUT	ECROU	MUTTER
52	12793301/0	2	VITE	SCREW	VIS	SCHRAUBE
54	☛	2	RUOTA POSTERIORE	REAR WHEEL	ROUE ARRIERE	HINTERRAD
	82680003/0		TURF SAVER CARLISLE	TURF SAVER CARLISLE	TURF SAVER CARLISLE	TURF SAVER CARLISLE
	82680006/0		DELI TIRE	DELI TIRE	DELI TIRE	DELI TIRE
55	82000592/0	2	CERCHIO RUOTA	RIMM	BANDAGE ROUE	HINTRERRAD FELGER
56	☛	2	PNEUMATICO	SHOE	PNEU	REIFEN
	25590001/0		TURF SAVER CARLISLE	TURF SAVER CARLISLE	TURF SAVER CARLISLE	TURF SAVER CARLISLE
	25590003/0		DELI TIRE	DELI TIRE	DELI TIRE	DELI TIRE
57	25670005/1	2	RONDELLA	WASHER	RONDELLE	SCHEIBE
58	12001010/0	2	ANELLO ELASTICO	SNAP RING	ANNEAU RESSORT	SPRENGRING
59	82110251/1	2	COPRIRUOTA POST.	REAR WHEEL DECK	COUVRE ROUE POST.	HINTERRADDECKEL
			(TC - TCR)	(TC - TCR)	(TC - TCR)	(TC - TCR)
	82110253/0	2	COPRIRUOTA POST. (TCP)	REAR WHEEL DECK (TCP)	COUVRE ROUE POST. (TCP)	HINTERRADDECKEL (TCP)
60	25430209/0	8	MOLLA AGGANCIAMENTO	SPRING	RESSORT	FEDER
61	22110230/0	2	COPRIMOZZO	HUB COVER	COUVRE MOYEU	RADNABE DECKEL
62	25950000/0	2	VALVOLA	VALVE	SOUPAPE	VENTIL

PER LA SOSTITUZIONE IN GARANZIA DELLE PARTI CONTRASSEGNALE CON «★» RIVOLGERSI AL SERVIZIO ASSISTENZA DEL COSTRUTTORE (TECUMSEH).

TO REPLACE UNDER GUARANTEE THE PARTS MARKED «★» SEEK ASSISTANCE FROM MANUFACTURER'S AFTER SALES SERVICE (TECUMSEH).
 POUR LE REMPLACEMENT, SOUS GARANTIE DES PIÈCES MARQUÉES AVEC «★» S'ADRESSER AU SERVICE APRÈS VENTES DU CONSTRUCTEUR (TECUMSEH).

ZUM AUSTAUSCH DER MIT «★» GEKENNZEICHNETEN TEILE IM RAHMEN DER GARANTIE, WENDEN SIE SICH AN DEN KUNDENDIENST DES HERSTELLERS (TECUMSEH).

TC102

TCP102

TCR102

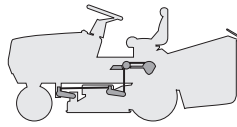

SOLLEVAMENTO PIATTO DI TAGLIO
CUTTING PLATE LIFTING
SOULEVEMENT PLATEAU DE COUPE
SCHNEIDWERKZEUG AUFHEBESATZ

2000

007.0

1 / 2

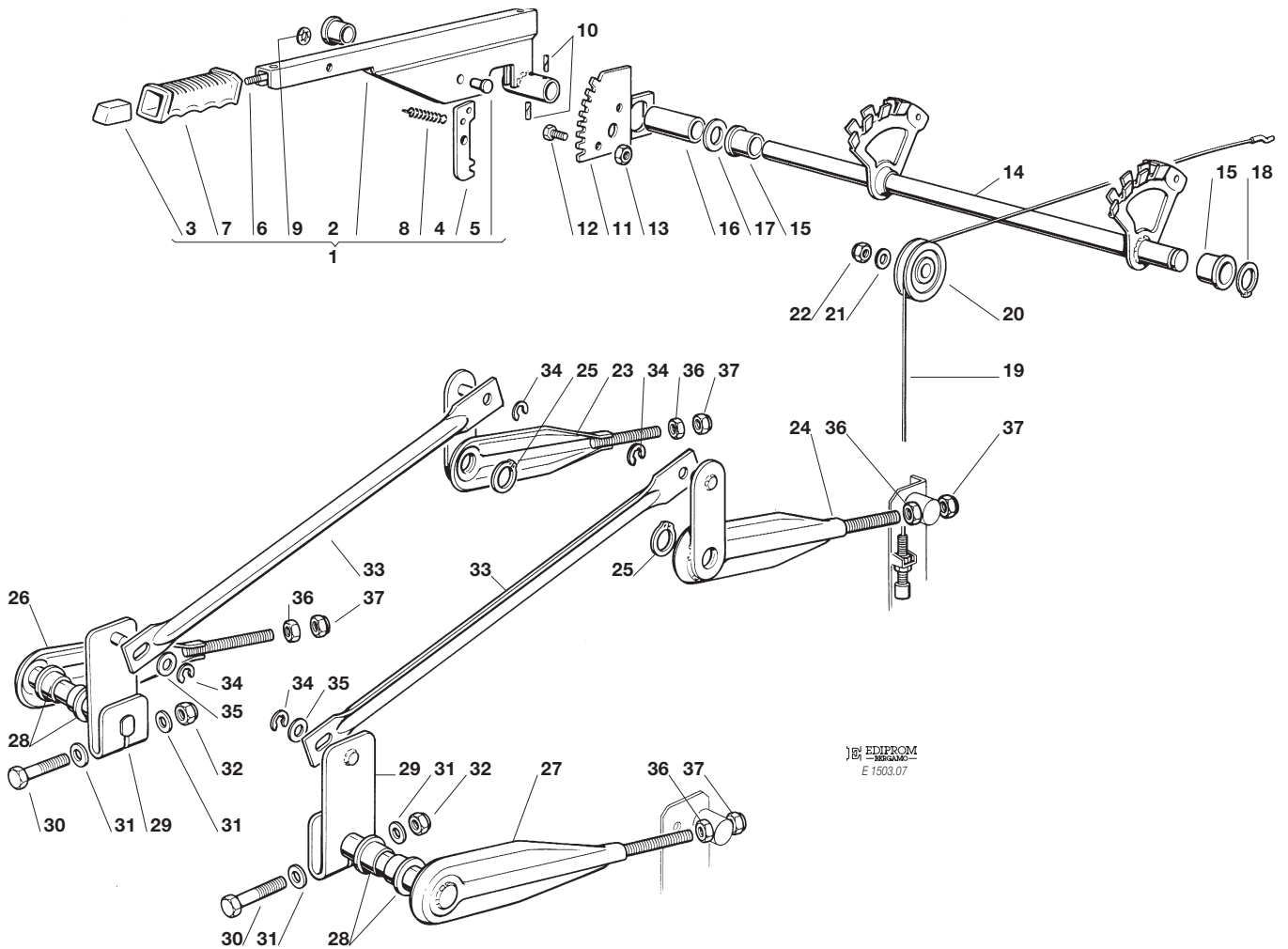

EDIPROM
E 1503.07

N.	CODE	Q.TY	DESCRIZIONE	DESCRIPTION	DESCRIPTION	BESCHREIBUNG
1	82300000/0	1	ASS. GRUPPO LEVA SOLLEVAMENTO PIATTO	LIFTING LEVER ASS.Y	ENS. LEVIER SOULEVEMENT PLATEAU DE COUPE	SCHNEIDWERKZEUG AUFHEBENHEBEL
2	82318103/0	1	LEVA SOLLEVAMENTO	LIFTING LEVER	LEVIER DE SOULEVEMENT	AUFHEBENHEBEL
3	25605000/1	1	PULSANTE	BUTTON	POUSSOIR	DRUCKKNOPF
4	25470901/0	1	NASELLO	DOG	DECLIC	NASE
5	25510011/0	1	PERNO	PIN	PIVOT	BOLZEN
6	25033002/0	1	ASTA COMANDO	PUSHROD	TIGE COMMANDE	BETAETIGUNGSSTAB
7	25394504/0	1	MANOPOLA	KNOB	POIGNEE	GRIFF
8	25430208/0	1	MOLLA	SPRING	RESSORT	FEDER
9	12604899/0	1	RONDELLA	WASHER	RONDELLE	SCHEIBE
10	12620206/0	1	SPINA	PIN	GOUPILLE	STIFT
11	25735501/1	1	SETTORE REGOLAZIONE	ADJ. SECTOR	SECTEUR REGLEMENT	EINSTELLESEKTOR
12	12792611/0	2	VITE	SCREW	VIS	SCHRAUBE
13	12293201/0	2	DADO	NUT	ECROU	MUTTER
14	82000401/1	1	ASS. ASSE SOLLEVAMENTO	LIFTING SHAFT	ARBRE SOULEVEMENT	AUFHEBENACHSE
15	22034523/0	3	BOCCOLA	BUSH	DOUILLE	BÜCHSE
16	25160004/0	1	DISTANZIALE	SPACER	ENTRETOISE	ENTFERNUNGSSTUECK
17	12521410/0	1	RONDELLA	WASHER	RONDELLE	SCHEIBE
18	12609260/0	1	SEEGER	SEEGER	SEEGER	SEEGER
19	82004600/0	2	ASS. FILO SOLLEVAMENTO	LIFTING WIRE	ENS. FIL SOULEVEMENT	AUFHEBENKABEL
20	25601557/0	2	PULEGGIA	PULLEY	POULIE	SCHEIBE
21	12521350/0	2	RONDELLA	WASHER	RONDELLE	SCHEIBE
22	12155000/0	2	DADO	NUT	ECROU	MUTTER
23	82318105/1	1	LEVA FULCRO DX	RIGHT FULCRUM LEVER	LEVIER POINT D'APPUI DROITE	RECHTER SCHWENKPUNKT HEBEL
24	82318107/1	1	LEVA FULCRO SX	LEFT FULCRUM LEVER	LEVIER POINT D'APPUI GAUCHE	LINKER SCHWENKPUNKT HEBEL
25	12609255/0	2	ANELLO	RING	ANNEAU	RING
26	82318115/0	1	LEVA FULCRO ANTERIORE DX	FRONT FULCRUM LEVER RIGHT	LEVIER POINT D'APPUI ANT. DROITE	RECHTER VORDERSCHWENK- PUNKTHEBEL



N.	CODE	Q.TY	DESCRIZIONE	DESCRIPTION	DESCRIPTION	BESCHREIBUNG
27	82318117/0	1	LEVA FULCRO ANTERIORE SX	FRONT FULCRUM LEVER LEFT	LEVIER POINT D'APPUI ANT. GAUCHE	LINKER VORDERSCHWENK- PUNKTHEBEL
28	25040605/0	4	BUSSOLA	BUSH	DOUILLE	BÜCHSE
29	82318109/0	2	LEVA ASTA COLLEGAMENTO	CONNECTING ROD LEVER	LEVIER TIGE DE CONNEXION	VERBINDUNGSSTAB HEBEL
30	12691700/0	2	VITE	SCREW	VIS	SCHRAUBE
31	12521350/0	4	RONDELLA	WASHER	RONDELLE	SCHEIBE
32	12155000/0	2	DADO	NUT	ECROU	MUTTER
33	25033001/0	2	ASTA COLLEGAMENTO	CONNECTING ROD	TIGE DE CONNEXION	VERBINDUNGSSTAB
34	12000955/0	4	ANELLO ELASTICO	SNAP RING	ANNEAU RESSORT	SPRENGRING
35	25670008/0	2	RONDELLA	WASHER	RONDELLE	SCHEIBE
36	12295200/0	4	DADO	NUT	ECROU	MUTTER
37	12156602/0	4	DADO	NUT	ECROU	MUTTER

TC102

TCP102

TCR102

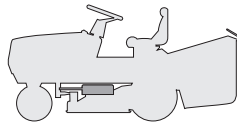

PIATTO DI TAGLIO (1)
CUTTING PLATE (1)
PLATEAU DE COUPE (1)
SCHNEIDWERKZEUG (1)

2000

008.0

1 / 2

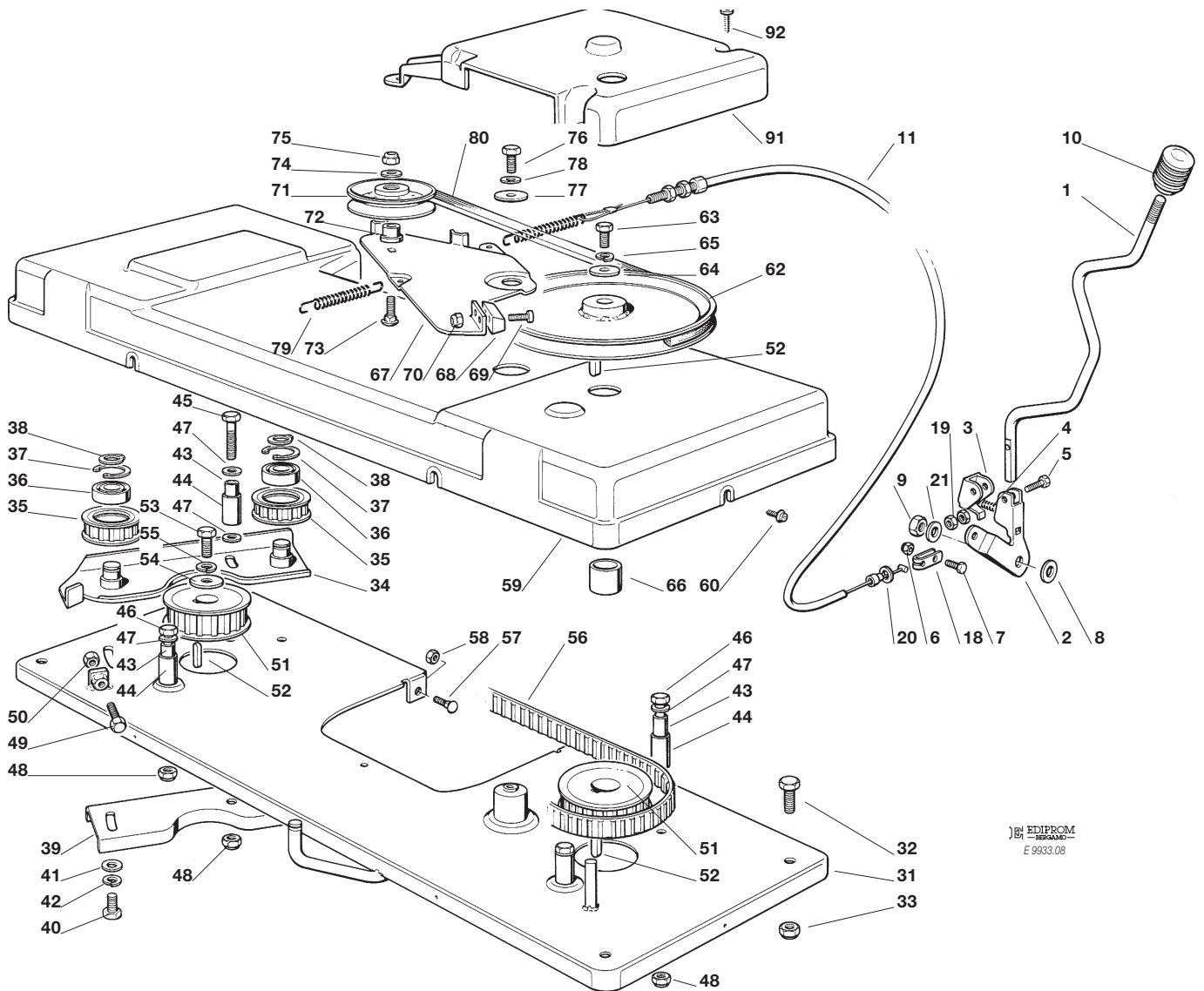

EDIPROM
E 9933.08

N.	CODE	Q.TY	DESCRIZIONE	DESCRIPTION	DESCRIPTION	BESCHREIBUNG
1	25318120/0	1	LEVA INNESTO	ENGAGING LEVER	LEVIER D'EMBRAYAGE	EINSCHALTENHEBEL
2	82774209/0	1	STAFFA LEVA	CLAMP LEVER	BRIDE POUR LEVIER	BRIDE FÜR HEBEL
3	25774211/1	1	STAFFA MOLLA	CLAMP SPRING	BRIDE POUR RESSORT	BRIDE FÜR FEDER
4	25430206/1	1	MOLLA	SPRING	RESSORT	FEDER
5	12674550/0	1	VITE	SCREW	VIS	SCHRAUBE
6	12154510/0	1	DADO	NUT	ECROU	MUTTER
7	12791213/0	1	VITE	SCREW	VIS	SCHRAUBE
8	22672151/0	1	RONDELLA	WASHER	RONDELLE	SCHEIBE
9	12155010/0	1	DADO	NUT	ECROU	MUTTER
10	25394503/1	1	MANOPOLA	HANDLE	POIGNÉE	GRIF
11	82004601/2	1	ASSIEME FILO	WIRE ASS.Y	ENSEMBLE FIL	KABEL
18	22061337/0	1	CAVALLOTTO	CONNECTING PLATE	PLAQUE DE CONNEXION	BUGEL BOLZEN
19	12292100/0	2	DADO	NUT	ECROU	MUTTER
20	12521350/0	1	RONDELLA	WASHER	RONDELLE	SCHEIBE
21	12523060/0	1	RONDELLA	WASHER	RONDELLE	SCHEIBE
31	82547003/2	1	PIASTRA	PLATE	PLATE	PLATTE
32	12792611/0	4	VITE	SCREW	VIS	SCHRAUBE
33	12293201/0	4	DADO	NUT	ECROU	MUTTER
34	82785084/1	1	SUPPORTO	SUPPORT	SUPPORT	HALTERSATZ
35	25601559/1	2	PULEGGIA	PULLEY	POULIE	RIEMENSCHLEIBE
36	19216033/1	2	CUSCINETTO	BEARING	ROULEMENT	KUGELLAGER
37	12610800/0	2	SEEGER	SEEGER	SEEGER	SEEGER
38	12609200/0	2	SEEGER	SEEGER	SEEGER	SEEGER



N.	CODE	Q.TY	DESCRIZIONE	DESCRIPTION	DESCRIPTION	BESCHREIBUNG
39	25650037/0	1	RINF. PULEGGE	PULLEY STIFFENING	REINFORCEMENT DES POULIE	RIEMENSCHLEIBE VERSTAERKUNG
40	12793102/0	2	VITE	SCREW	VIS	SCHRAUBE
41	12521350/0	2	RONDELLA	WASHER	RONDELLE	SCHEIBE
42	12583500/0	2	GROWER	GROWER	GROWER	GROWER
43	25160003/0	4	DISTANZIALE	SPACER	ENTRETOISE	DISTANZRING
44	25038000/0	4	BOCCOLA	BUSHING	DOUILLE	BUCHSE
45	12691700/0	1	VITE	SCREW	VIS	SCHRAUBE
46	12691200/0	3	VITE	SCREW	VIS	SCHRAUBE
47	12521350/0	5	RONDELLA	WASHER	RONDELLE	SCHEIBE
48	12155000/0	4	DADO	NUT	ECROU	MUTTER
49	12793900/0	1	VITE	SCREW	VIS	SCHRAUBE
50	12293200/0	1	DADO	NUT	ECROU	MUTTER
51	25601560/0	2	PULEGGIA	PULLEY	POULIE	RIEMENSCHLEIBE
52	12139480/0	3	CHIAVETTA	KEY	CLAVETTE	KEIL
53	12793102/0	1	VITE	SCREW	VIS	SCHRAUBE
54	25670007/0	1	RONDELLA	WASHER	RONDELLE	SCHEIBE
55	12583500/0	1	GROWER	GROWER	GROWER	GROWER
56	35065600/0	1	CINGHIA	BELT	COURROIRE	KEILRIEMEN
57	12815200/0	3	VITE	SCREW	VIS	SCHRAUBE
58	12292102/0	3	DADO	NUT	ECROU	MUTTER
59	25060100/2	1	CARTER	CASE	CARTER	BLECH
60	12735110/0	6	VITE	SCREW	VIS	SCHRAUBE
62	25601550/0	1	PULEGGIA	PULLEY	POULIE	RIEMENSCHLEIBE
63	12793102/0	1	VITE	SCREW	VIS	SCHRAUBE
64	25670007/0	1	RONDELLA	WASHER	RONDELLE	SCHEIBE
65	12583500/0	1	GROWER	GROWER	GROWER	GROWER
66	25160002/0	1	DISTANZIALE	SPACER	ENTRETOISE	DISTANZRING
67	25318115/1	1	LEVA FRENO	BRAKE LEVER	LEVIER FREIN	BREMSHEBEL
68	25207000/1	1	FERODO	LINING	PASTILLE FREIN	BREMSBELAG
69	12771400/0	2	VITE	SCREW	VIS	SCHRAUBE
70	12154330/0	2	DADO	NUT	ECROU	MUTTER
71	25601555/0	1	PULEGGIA	PULLEY	POULIE	RIEMENSCHLEIBE
72	25160007/0	1	DISTANZIALE	SPACER	ENTRETOISE	DISTANZRING
73	12818900/0	1	VITE	SCREW	VIS	SCHRAUBE
74	12523060/0	1	RONDELLA	WASHER	RONDELLE	SCHEIBE
75	12155000/0	1	DADO	NUT	ECROU	MUTTER
76	12793102/0	1	VITE	SCREW	VIS	SCHRAUBE
77	12523070/0	1	RONDELLA	WASHER	RONDELLE	SCHEIBE
78	12583500/0	1	GROWER	GROWER	GROWER	GROWER
79	25430210/0	1	MOLLA FRENO LAMA	BLADE BRAKE SPRING	RESSORT FREIN LAME	MESSER BREMSE FEDER
80	35062813/0	1	CINGHIA	BELT	COURROIE	KEIL RIEMEN
91	25600049/0	1	PROTEZIONE CINGHIA POST.	REAR BELT PROTECTION	PROTECTION COURROIRE POSTERIEURE	HINTERR RIEMENSCHUTZ
92	12735402/0	3	VITE	SCREW	VIS	SCHRAUBE

TC102

TCP102

TCR102

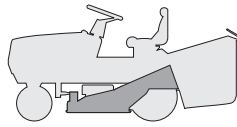

PIATTO DI TAGLIO (2)
CUTTING PLATE (2)
PLATEAU DE COUPE (2)
SCHNEIDWERKZEUG (2)

2000

009.0

1 / 2

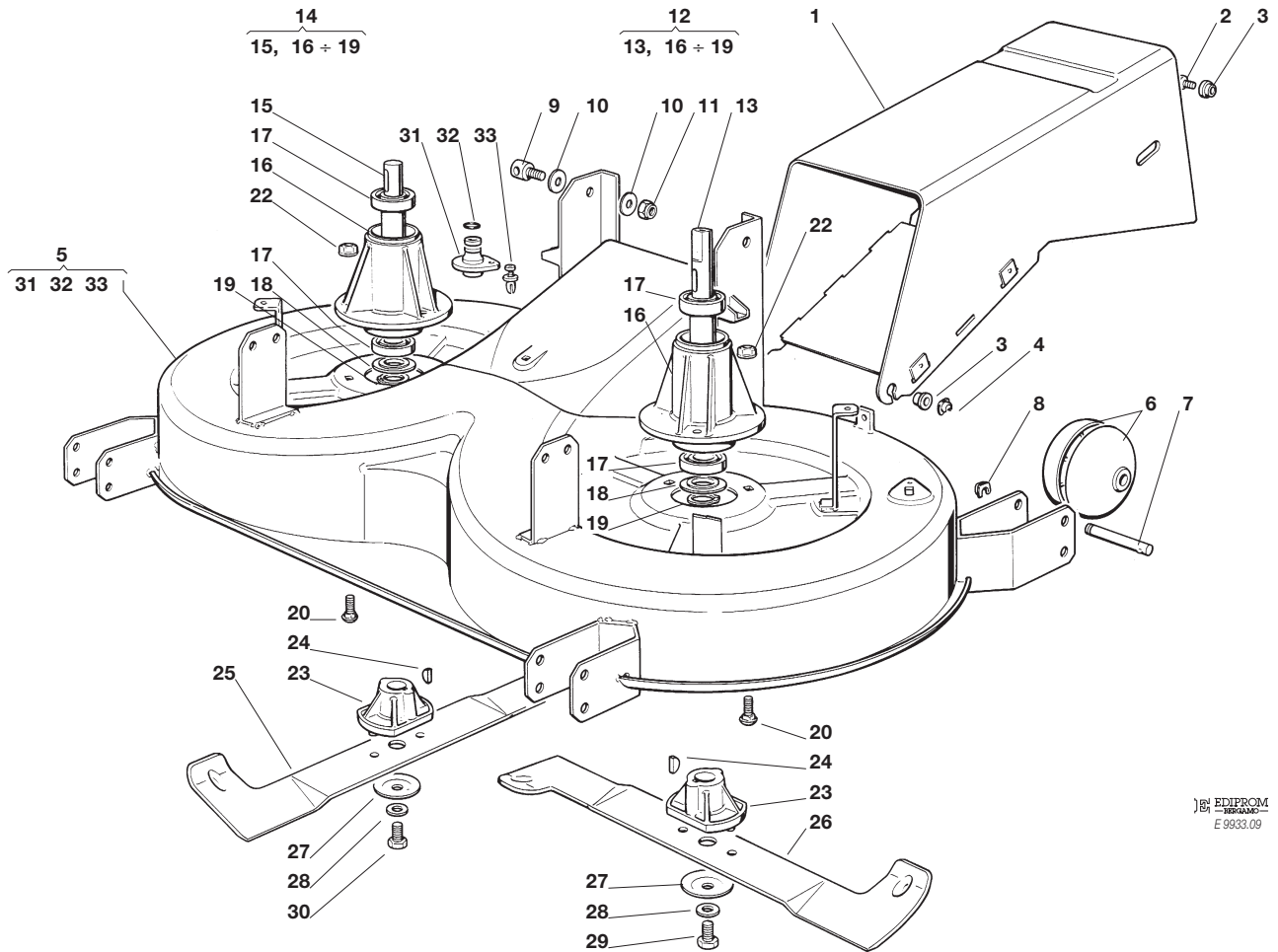

EDIPROM
E 9933.09

N.	CODE	Q.TY	DESCRIZIONE	DESCRIPTION	DESCRIPTION	BESCHREIBUNG
1	82108010/0	1	CONVOGLIATORE POSTER.	REAR CONVEYOR ASS.Y	ENS. CONVOYEUR POST.	HINTERLEITBLECHSATZ
2	12793102/0	2	VITE	SCREW	VIS	SCHRAUBE
3	25038002/0	4	BOCCOLA	BUSHING	DOUILLE	BUCHSE
4	12436050/0	2	PIASTRINA	PLATE	PLAQUE	PLATTE
5	82565005/0	1	ASSIEME PIATTO DI TAGLIO (+32-33-34)	CUTTING PLATE ASS.Y (+32-33-34)	ENS. PLATEAU DE COUPE (+32-33-34)	SCHNEIDWERKZEUG (+32-33-34)
6	82700000/0	4	RUOTINO ANTISCALPO	LEVELLING SMALL WHEEL	ROULETTES ANTISCALP	EBENUNGRAEDCHEN
7	25510006/0	4	PERNO	PIN	PIVOT	BOLZEN
8	12436030/0	4	PIASTRINA	PLATE	PLAQUE	PLATTE
9	25510024/0	4	PERNO	PIN	PIVOT	BOLZEN
10	25670008/0	8	RONDELLA	WASHER	RONDELLE	SCHEIBE
11	12156602/0	4	DADO	NUT	ECROU	MUTTER
12	82207200/1	1	ASS. FLANGIA ALBERO PRINCIPALE (13, 16÷19)	BLADE MAIN SHAFT SUPPORT (13, 16÷19)	SUPPORT ARBRE LAME PRINCIPAL (13, 16÷19)	MESSERWELLEHAFT- SATZ (13, 16÷19)
13	25020800/1	1	ALBERO LAMA PRINCIPALE	MAIN BLADE SHAFT	ARBRE LAME PRINCIPAL	HAUP MESSERWELLE
14	82207201/2	1	ASS. FLANGIA ALBERO SECONDARIO (15, 16÷19)	BLADE SECONDARY SHAFT SUPPORT (15, 16÷19)	SUPPORT ARBRE LAME SECONDAIRE (15, 16÷19)	MASSERWELLE ZWEITER- SATZ (15, 16÷19)
15	25020801/2	1	ALBERO LAMA SECONDARIO	SECONDARY BLADE SHAFT	ARBRE LAME SECONDAIRE	ZWEITE MESSERWELLE
16	25207200/0	2	FLANGIA ALBERO LAMA	BLADE SHAFT SUPPORT	SUPPORT ARBRE LAME	MESSERWELLE
17	19216032/0	4	CUSCINETTO	BEARING	ROULEMENT	KUEGELLAGER
18	25160501/0	2	DISCO PARAPOLVERE	DUST COVER	PROTEGE-POUSSIERE	STAUBSCHUTTSCHIEBE
19	12609260/0	2	SEEGER	SEEGER	SEEGER	SEEGER
20	12818700/0	6	VITE	SCREW	VIS	SCHRAUBE
22	12154210/0	6	DADO	NUT	ECROU	MUTTER
23	25463200/0	2	MOZZO COLTELLO	BLADE HUB	MOYEU LAME	MESSERHALTER
24	12139100/0	2	LINGUETTA	KEY	CLAVETTE	KEIL
25	82004341/0	1	COLTELLO DX	RIGHT BLADE	LAME DROITE	RECHTER MESSER
26	82004340/0	1	COLTELLO SX	LEFT BLADE	LAME GAUCHE	LINKER MESSER
27	22160400/0	2	DISCO ELASTICO	ELASTIC WASHER	RONDELLE ELASTIQUE	FEDERSCHIEBE
28	12523080/0	2	RONDELLA	WASHER	RONDELLE	SCHEIBE
29	12735694/0	1	VITE	SCREW	VIS	SCHRAUBE



N.	CODE	Q.TY	DESCRIZIONE	DESCRIPTION	DESCRIPTION	BESCHREIBUNG
30	12735695/1	1	VITE	SCREW	VIS	SCHRAUBE
31	25033060/0	2	ATTACCO TUBO ACQUA	WATER HOSE CONNECTION	RACCORD TUYAU D'EAU	WASSERANSCHLUSS
32	19035000/0	2	ANELLO OR	O RING	O RING	O RING
33	12500030/0	2	RIVETTO	RIVET	RIVET	NIET
—	82565000/1	1	PIATTO DI TAGLIO ASSEMBLATO (008, 31÷92 + 009, 5÷33)	CUTTING PLATE, ASSEMBLED (008, 31÷92 + 009, 5÷33)	PLATEAU DE COUPE,S COMPLETE (008, 31÷92 + 009, 5÷33)	CHNEIDWERKZEUG, KOMPLETT (008, 31÷92 + 009, 5÷33)

TC102

TCP102

TCR102

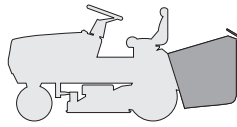

SACCO
GRASSCATCHER
BAC
AUFFANGSACK

2000

010.0

1 / 2

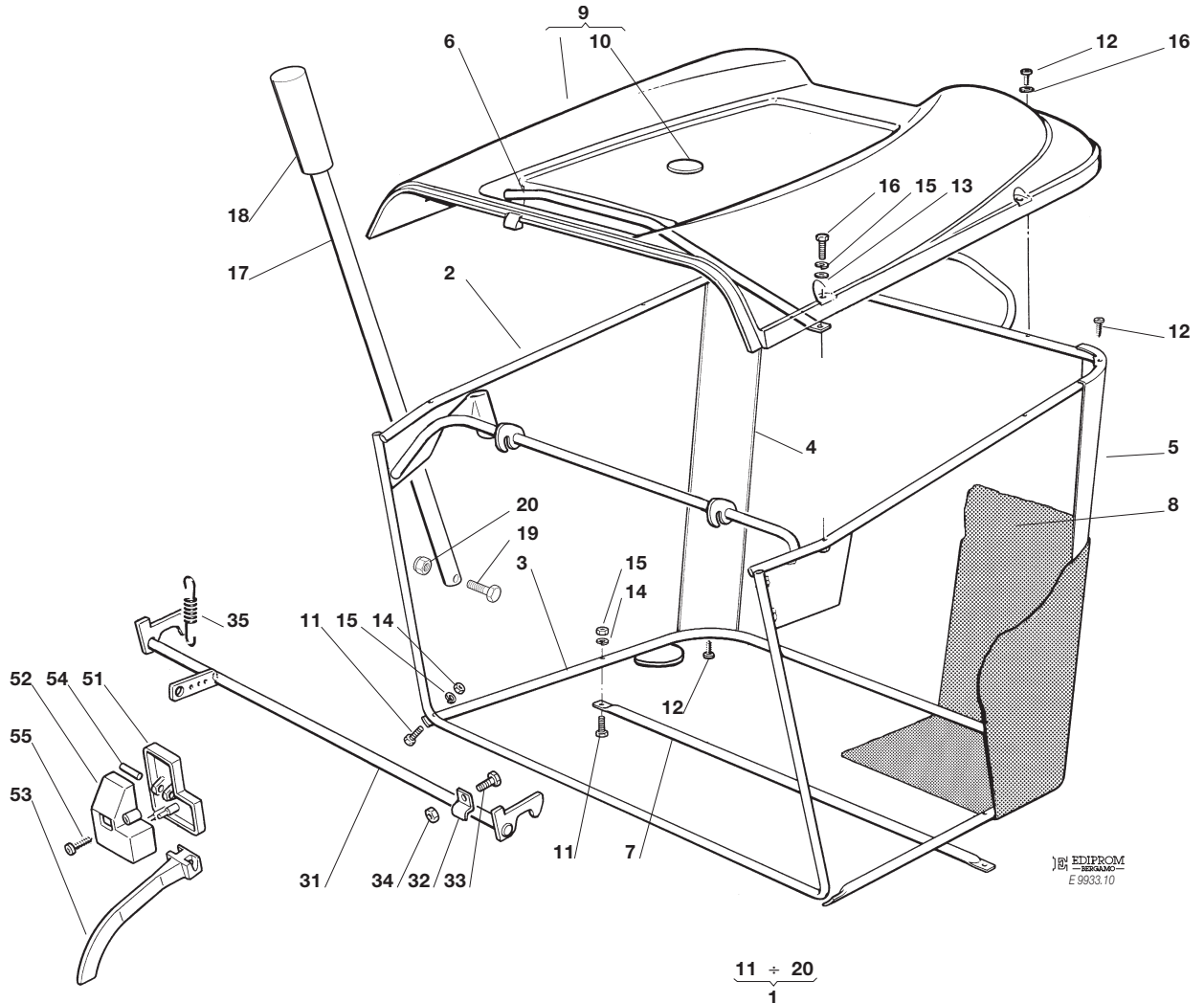

EDIPROM
E 9933.10

11 ÷ 20
1

N.	CODE	Q.TY	DESCRIZIONE	DESCRIPTION	DESCRIPTION	BESCHREIBUNG
1	82180000/2	1	DOTAZIONE SACCO	GRASS-BOX OUTFIT	DOTATION BAC	KORBAUS TATTUNG
2	82800043/0	1	TELAIO SUP.	UPPER FRAME	CHASSIS SUPERIEUR	OBERERRAHMEN
3	82800002/1	1	TELAIO INF.	LOWER FRAME	CHASSIS INFÉRIEUR	UNTERERRAHMEN
4	25032001/1	1	ANGOLARE DX	RIGHT ANGULAR SUPPORT	SUPPORT ANG. DROITE	RECHTER HALTER
5	25032002/1	1	ANGOLARE SX	LEFT ANGULAR SUPPORT	SUPPORT ANG. GAUCHE	LINKER HALTER
6	82394001/1	1	MANIGLIA ANT.	FRONT HANDLE	POIGNEE ANTERIEURE	VORDERGRIFF
7	82650038/0	1	RINFORZO INF.	LOWER STIFFENING	RENFORCEMENT SUPER.	OBERE VERSTAERKUNG
8	82106000/2	1	SACCO	GRASSCATCHER	SAC	SACK
9	☛	1	COPERT. SACCO (TC-TCR)	GRASSC. PLASTIC (TC-TCR)	SAC COUVERTURE (TC-TCR)	SACKABDECKUNG (TC-TCR)
	82110191/0		ROSSA	RED	ROUGE	ROT
	82110192/0		VERDE	GREEN)	VERT	GRÜN
	82110193/0		GIALLA	YELLOW	JAUNE	GELB
	82110194/0		BLU	BLUE	BLEU	BLAU
	82110196/0		ARANCIONE	ORANGE	ORANGE	DUNKELORANGE
	☛	1	COPERTURA SACCO (TCP)	GRASSCAT. PLASTIC (TCP)	SAC COUVERTURE (TCP)	SACKABDECKUNG (TCP)
	82110170/0		ROSSA	RED	ROUGE	ROT
	82110171/0		VERDE	GREEN	VERT	GRÜN
	82110172/0		GIALLA	YELLOW	JAUNE	GELB
	82110173/0		BLU	BLUE	BLEU	BLAU
10	☛	1	PIASTRINA (TC - TCR)	PLATE (TC - TCR)	PLAQUE (TC - TCR)	PLATTE (TC - TCR)
	25547016/1		ROSSA	RED	ROUGE	ROT
	25547015/0		VERDE	GREEN	VERT	GRÜN
	25547014/0		GIALLA	YELLOW	JAUNE	GELB
	25547024/0		BLU	BLUE	BLEU	BLAU
	25547093/0		ARANCIONE	ORANGE	ORANGE	DUNKELORANGE
	☛	1	PIASTRINA (TCP)	PLATE (TCP)	PLAQUE (TCP)	PLATTE (TCP)
	25547025/0		ROSSA	RED	ROUGE	ROT
	25547026/0		VERDE	GREEN	VERT	GRÜN
	25547027/0		GIALLA	YELLOW	JAUNE	GELB
	25547028/0		BLU	BLUE	BLEU	BLAU
11	12792099/0	4	VITE	SCREW	VIS	SCHRAUBE

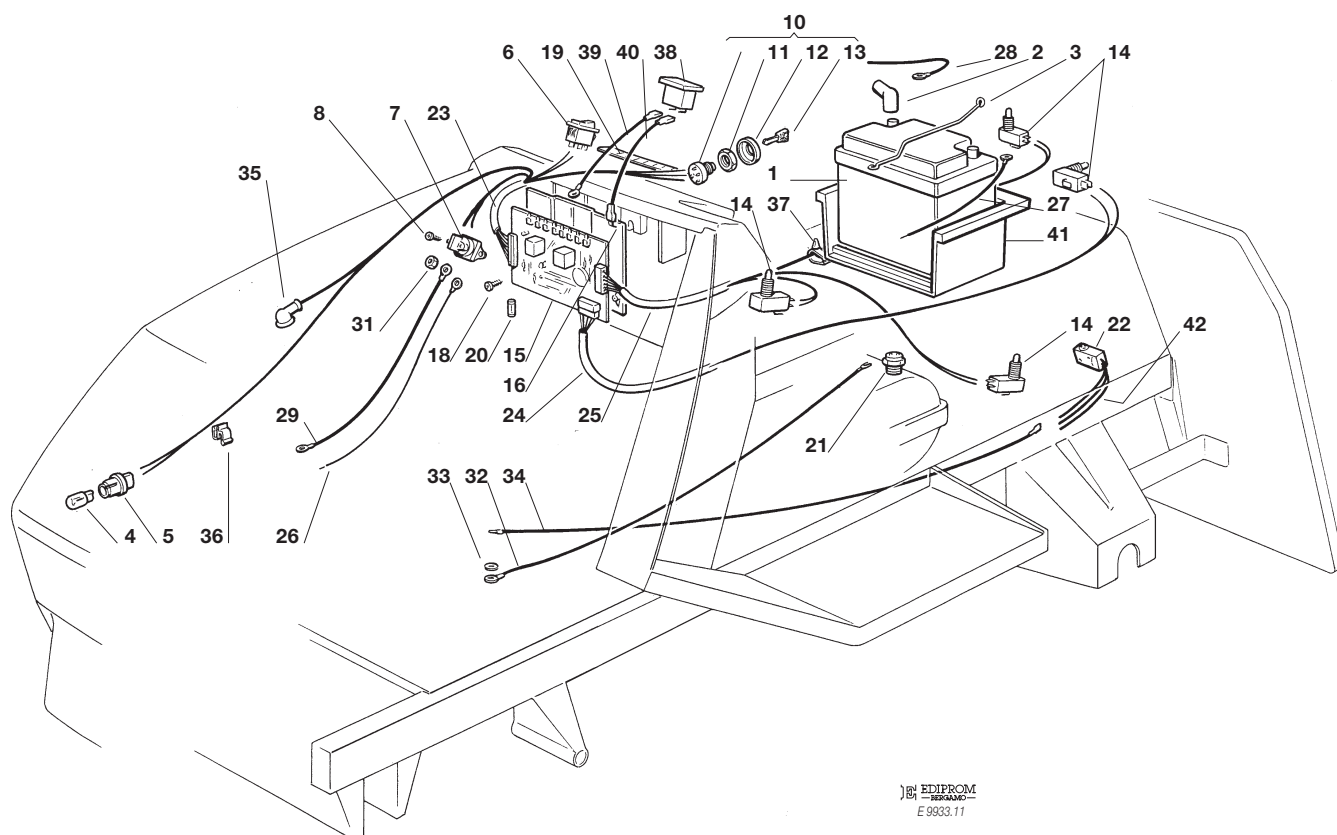
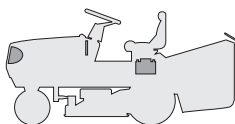

N.	CODE	Q.TY	DESCRIZIONE	DESCRIPTION	DESCRIPTION	BESCHREIBUNG
12	12729601/0	8	VITE	SCREW	VIS	SCHRAUBE
13	12674701/0	2	VITE	SCREW	VIS	SCHRAUBE
14	12292100/0	4	DADO	NUT	ECROU	MUTTER
15	12582101/0	6	GROWER	GROWER	GROWER	GROWER
16	12521331/0	6	RONDELLA	WASHER	RONDELLE	SCHEIBE
17	25869029/1	1	TUBO	ROD	TIGE	STANGE
18	25394508/0	1	MANOPOLA	HANDLE	POINGEE	GRIFF
19	12792099/0	1	VITE	SCREW	VIS	SCHRAUBE
20	12154510/0	1	DADO	NUT	ECROU	MUTTER
31	82000483/0	1	ASTA AGGANCIAMENTO SACCO INF.	LOWER COUPLING ROD	TIGE D'ACCROCHAGE INF.	UNTERE KUPPLUNGSTANGE
32	25774220/0	2	STAFFA ANCORAGGIO	ANCHOR BRACKET	ETRIER	BRIDE
33	12791200/0	2	VITE	SCREW	VIS	SCHRAUBE
34	12292102/0	2	DADO	NUT	ECROU	MUTTER
35	25430220/0	1	MOLLA	SPRING	RESSORT	FEDER
51	25600040/0	1	COPERCHIO PROTEZIONE	PROTECTION	PROTECTION	SHUTZ
52	25600039/0	1	PROTEZIONE MICRO	MICRO PROTECTION	PROTECTION MICRO	SCHUTZ
53	25318112/0	1	LEVA	LEVER	LEVIER	HEBEL
54	12400030/0	1	PERNO	PIN	PIVOT	BOLZEN
55	12728440/0	2	VITE	SCREW	VIS	SCHRAUBE

 EDIPROM
 E 9933.11

N.	CODE	Q.TY	DESCRIZIONE	DESCRIPTION	DESCRIPTION	BESCHREIBUNG
1	18120002/1	1	BATTERIA 12 V - 18 Ah	BATTERY 12 V - 18 Ah	BATTERIE 12 V - 18 Ah	BATTERIE 12 V - 18 Ah
2	18564862/0	1	PROTEZIONE	PROTECTION	PROTECTION	SCHUTZ
3	25430200/0	2	MOLLA	SPRING	RESSORT	FEDER
4	18459100/0	2	LAMPADA	FARILAMP FOR LIGHTS	LAMPE POUR PHARES	LAMPENFASSUN
5	33500030/0	2	PORTALAMPADE	LAMP HOLDER	DOUILLE DE LAMPE	SCHEINWERFERLAMPE
6	18450060/0	1	INTERRUTTORE	FARILAMP SWITCH	INTERRUPTEUR PHARES	LICHTEN SCHALTER
7	18736110/0	1	RELÉ AVVIAMENTO	STARTER RELAY	RELAIS D'ALLUMAGE	ANLASSRELAIS
8	12735110/0	2	VITE	SCREW	VIS	SCHRAUBE
10	18450065/1	1	INTERRUTTORE AVVIAMENTO	STARTING SWITCH	INTERRUPTEUR DEMARRAGE	SCHALTER
11	18400861/0	1	GHIERA	SCREWED RING	EMBOUT	NUTMUTTER
12	18565351/0	1	PROTEZIONE GHIERA	SCREWED RING PROTECTION	PROTECTION EMBOUT	NUTMUTTER SCHUTZ
13	18210016/0	1	CHIAVE AVVIAMENTO	STARTING KEY	CLEF A DEMARRAGE	SCHLÜSSEL FÜR START
14	19410603/1	4	MICRO INTERRUTTORE	MICRO	MICRO	MIKRO
15	25722406/0	1	SCHEDA ELETTRONICA	ELECTRONIC CARD	CARTE ELECTRONIQUE	ELEKTRONISCHE KARTE
			6 FUNZIONI	6 FUNCTIONS	6 INDICAT.	6 ANGABEN
			12 - 12,5 - 13 - 15,5 HP B&S	12 - 12,5 - 13 - 15,5 HP B&S	12 - 12,5 - 13 - 15,5 HP B&S	12 - 12,5 - 13 - 15,5 HP B&S
			13 - 15 HP TECUMSEH	13 - 15 HP TECUMSEH	13 - 15 HP TECUMSEH	13 - 15 HP TECUMSEH
	25722407/0		8 FUNZIONI - 18 HP B&S	8 FUNCTIONS - 18 HP B&S	8 INDICAT. - 18 HP B&S	8 ANGABEN - 18 HP B&S
16	25600007/0	1	PROTEZIONE SCHEDA	CARD PROTECTION	PROTECTION CARTE	KARTESCHUTZ
			(TC - TCR)	(TC - TCR)	(TC - TCR)	(TC - TCR)
16	25600009/0	1	PROTEZIONE SCHEDA (TCP)	CARD PROTECTION (TCP)	PROTECTION CARTE (TCP)	KARTESCHUTZ (TCP)
18	12735105/0	3	VITE	SCREW	VIS	SCHRAUBE
19	25420000/1	1	MEMBRANA	CHECK CONTROLL	PANNEAU DE CONTROLE	KONTROLLTAFEL
			(6 FUNZ.)	(6 FUNCTIONS)	(6 INDICATIONS)	(6 ANGABEN)
	25420001/1	1	MEMBRANA	CHECK CONTROLL	PANNEAU DE CONTROLE	KONTROLLTAFEL
			(8 FUNZ.)	(8 FUNCTIONS)	(8 INDICATIONS)	(8 ANGABEN)
20	33340033/0	1	FUSIBILE 6,3 Amp. T	FUSE 6.3 Amp. T	FUSIBLE 6,3 Amp. T	SICHERUNG 6,3 Amp. T
21	19410604/0	1	INTERRUTTORE CAMBIO	GEARBOX SWITCH	INT. BOÎTE DE VITESSE	ANTRIEB SCHALTER
22	19410605/1	1	MICRO SACCO PIENO	FULL GRASSCATCHER	MICRO BAC PLEIN	VOLLKORB VORRICHTUNG
				MICROSWITCH		



N.	CODE	Q.TY	DESCRIZIONE	DESCRIPTION	DESCRIPTION	BESCHREIBUNG
23	82040024/0	1	ASS. CABLAGGIO 12 - 12,5 - 13 HP B&S 13 - 15 HP TECUMSEH 15,5HP B&S	CABLES ASS.Y 12 - 12,5 - 13 HP B&S 13 - 15 HP TECUMSEH 15,5HP B&S	ENS. CABLAGES 12 - 12,5 - 13 HP B&S 13 - 15 HP TECUMSEH 15,5HP B&S	KABELSATZ 12 -12,5 - 13 HP B&S 13 - 15 HP TECUMSEH 15,5HP B&S
24	82040004/1	1	ASS. CABLAGGIO 12 - 12,5 - 13 - 15,5 HP B&S 13 - 15 HP TECUMSEH 18 HP B&S	CABLES ASS.Y 12 - 12,5 - 13 - 15,5 HP B&S 13 - 15 HP TECUMSEH 18 HP B&S	ENS. CABLAGES 12 - 12,5 - 13 - 15,5 HP B&S 13 - 15 HP TECUMSEH 18 HP B&S	KABELSATZ 12 - 12,5 - 13 - 15,5 HP B&S 13 - 15 HP TECUMSEH 18 HP B&S
25	82040029/1	1	ASS. CABLAGGIO 12 - 12,5 - 13 - 15,5 HP B&S 13 - 15 HP TECUMSEH 18 HP B&S	CABLES ASS.Y 12 - 12,5 - 13 - 15,5 HP B&S 13 - 15 HP TECUMSEH 18 HP B&S	ENS. CABLAGES 12 - 12,5 - 13 - 15,5 HP B&S 13 - 15 HP TECUMSEH 18 HP B&S	KABELSATZ 12 - 12,5 - 13 - 15,5 HP B&S 13 - 15 HP TECUMSEH 18 HP B&S
26	25065003/0	1	CAVO RICARICA	CABLE	CABLES	KABEL
27	25065004/0	1	CAVO MASSA BATTERIA	CABLE	CABLES	KABEL
28	25065001/0	1	CAVO BATT. SOLENOIDE	CABLE	CABLES	KABEL
29	25065002/0	1	CAVO SOLENOIDE MOT.	CABLE	CABLES	KABEL
31	12360352/0	2	DADO	NUT	ECROU	MUTTER
32	25065005/0	1	CAVO MASSA	CABLE	CABLES	KABEL
33	12540260/0	1	RONDELLA	WASHER	RONDELLE	SCHEIBE
34	25065011/0	1	CAVO COLL. MICRO	CABLE	CABLES	KABEL
35	18564861/0	1	CAPPUCCIO PROTEZIONE	PROTECTION	PROTECTION	SCHUTZ
36	33320505/0	1	FERMACAVO	FAIRLED	FIXATION CABLE	KABELBEFESTIGUNG
37	33320506/0	2	FERMACAVO	FAIRLED	FIXATION CABLE	KABELBEFESTIGUNG
38	18230000/0	1	CONTAORE (TCP)	HOUR COUNTER (TCP)	COMPTE-HEURS (TCP)	BETRIEBESSTUNDENZÄHLER (TCP)
39	25065009/0	1	CAVO (TCP)	CABLE (TCP)	CABLES (TCP)	KABEL (TCP)
40	25065010/1	1	CAVO (TCP)	CABLE (TCP)	CABLES (TCP)	KABEL (TCP)
41	25785010/0	1	SUPPORTO BATTERIA	BATTERY HOLDER	SUPPORT BATTERIE	BATTERIE STÜTZE
42	25065023/0	1	CAVO	CABLE	CABLES	KABEL

TC102

TCP102

TCR102

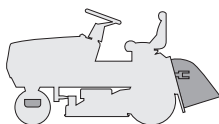

ACCESSORI A RICHIESTA
 OPTIONALS ON REQUEST
 ACCESSOIRES SUR DEMANDE
 ZUBEHOERE NACH ANFRAGE

1999

012.0

1 / 1

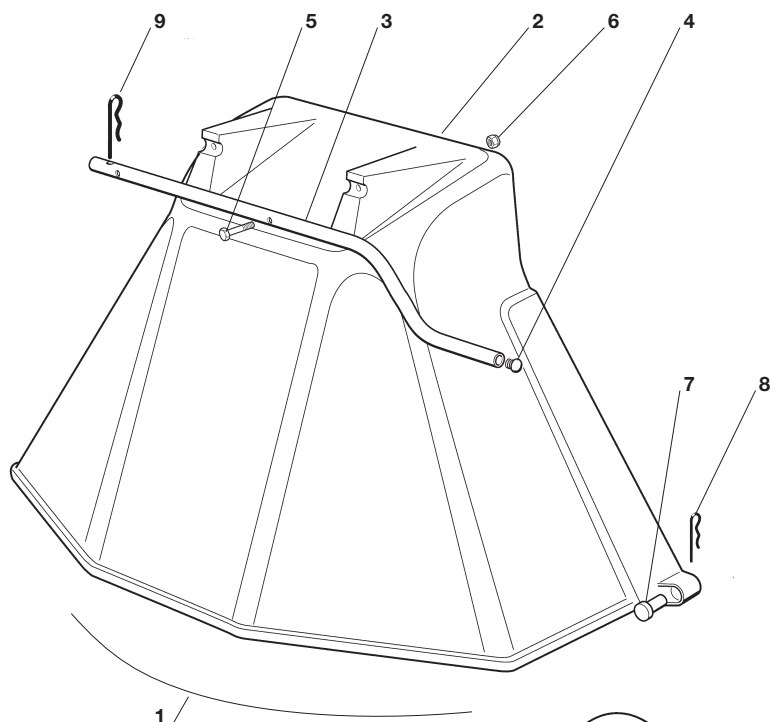
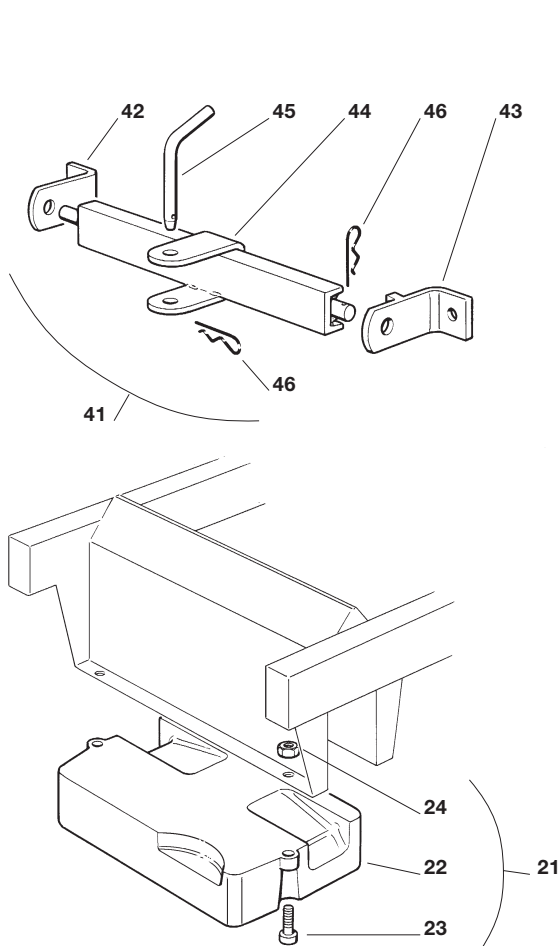

EDIPROM
 E 9933.12

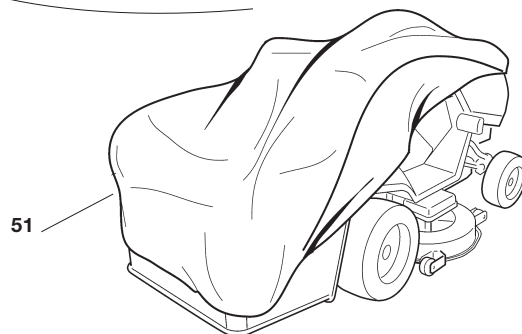

N.	CODE	Q.TY	DESCRIZIONE	DESCRIPTION	DESCRIPTION	BESCHREIBUNG
1	99900015/0	1	ASS. KIT PROTEZIONE USCITA	EJECTION-GUARD ASS.Y	KIT PROTECTION SORTIE	VORRICHTUNG FÜR AUSWURESCHUTZ
2	82400003/0	1	PROTEZIONE USCITA	EJECTION GUARD	PROTECTION SORTIE	AUSWURFSCHUTZ
3	25869043/0	1	TUBO DI AGGANCIO	SUPPORT	SOPPORT	HALTER
4	18566110/0	2	PUNTALE	CAP	BOUCHON	PFROFFEN
5	12689515/0	2	VITE	SCREW	VIS	SCHRAUBE
6	12154510/0	2	DADO	NUT	ECROU	MUTTER
7	25510022/0	2	PERNO	PIN	PIVOT	BOLZEN
8	24487998/0	2	COPPIGLIA	COTTER PIN	GOUPILLE	SPLIT
9	24487999/0	1	COPPIGLIA	COTTER PIN	GOUPILLE	SPLIT
21	99900030/5	1	ASS. KIT PESO ANT.	FRONT WEIGHT KIT	KIT POIDS ANTERIEUR	VORDERGEWICHT VORRICHTUNG
22	25519997/0	1	PESO	WEIGHT	POIDS	GEWICHT
23	12760520/0	3	VITE	SCREW	VIS	SCHRAUBE
24	12155000/0	3	DADO	NUT	ECROU	MUTTER
41	99900000/0	1	ASS. KIT TRAINO	HITCH KIT	KIT DE TRAINAGE	ZUGVORRICHTUNG
42	82735502/0	1	STAFFA SUPPORTO TRAINO DX	BRACKET RIGHT HITCH SUPPORT	ETRIER SUPPORT TRAINAGE DROITE	BUEGEL HALTER FÜR RECHTEN ZUG
43	25774213/0	1	STAFFA SUPPORTO TRAINO SX	BRACKET LEFT HITCH SUPPORT	ETRIER SUPPORT TRAINAGE GAUCHE	BUEGELHALTER FÜR LINKEN ZUG
44	82033101/0	1	BARRA	ROD	BARRE	STANGE
45	25510021/0	1	PERNO	PIN	PIVOT	BOLZEN
46	24487999/0	2	COPPIGLIA	COTTER PIN	GOUPILLE	SPLIT
51	18737950/0	1	TELO DI COPERTURA	CLOTH	BÂCHE	PLANE

TC102

TCP102

TCR102

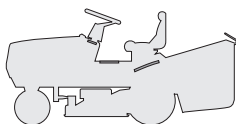

ETICHETTE
LABELS
ETIQUETTES
KLEBZETTEL

2000

013.0

1 / 1

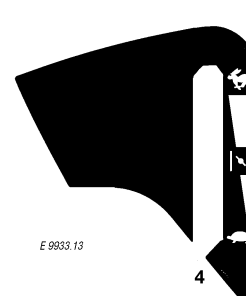
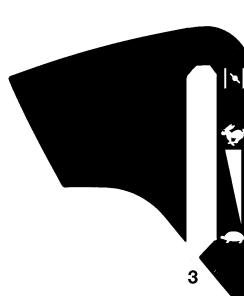
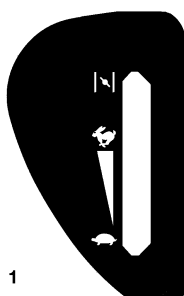
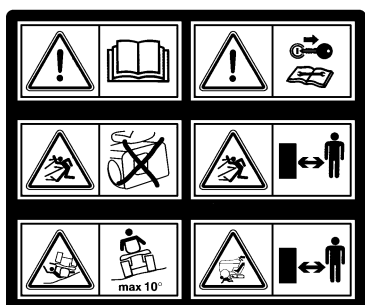

E 9933.13

N.	CODE	Q.TY	DESCRIZIONE	DESCRIPTION	DESCRIPTION	BESCHREIBUNG
1	14357190/0	1	ETICHETTA	LABEL	ETIQUETTE	KLEBZETTEL
2	14356754/1	1	ETICHETTA (TCP)	LABEL (TCP)	ETIQUETTE (TCP)	KLEBZETTEL (TCP)
3	14356177/2	1	ETICHETTA (TC - TCR)	LABEL (TC - TCR)	ETIQUETTE (TC - TCR)	KLEBZETTEL (TC - TCR)
4	14357184/2	1	ETICHETTA (TC - TCR)	LABEL (TC - TCR)	ETIQUETTE (TC - TCR)	KLEBZETTEL (TC - TCR)
5	14357177/1	1	ETICHETTA	LABEL	ETIQUETTE	KLEBZETTEL
6	14356700/1	1	ETICHETTA	LABEL	ETIQUETTE	KLEBZETTEL
7	14356757/1	1	ETICHETTA	LABEL	ETIQUETTE	KLEBZETTEL
8	14356185/1	1	ETICHETTA	LABEL	ETIQUETTE	KLEBZETTEL

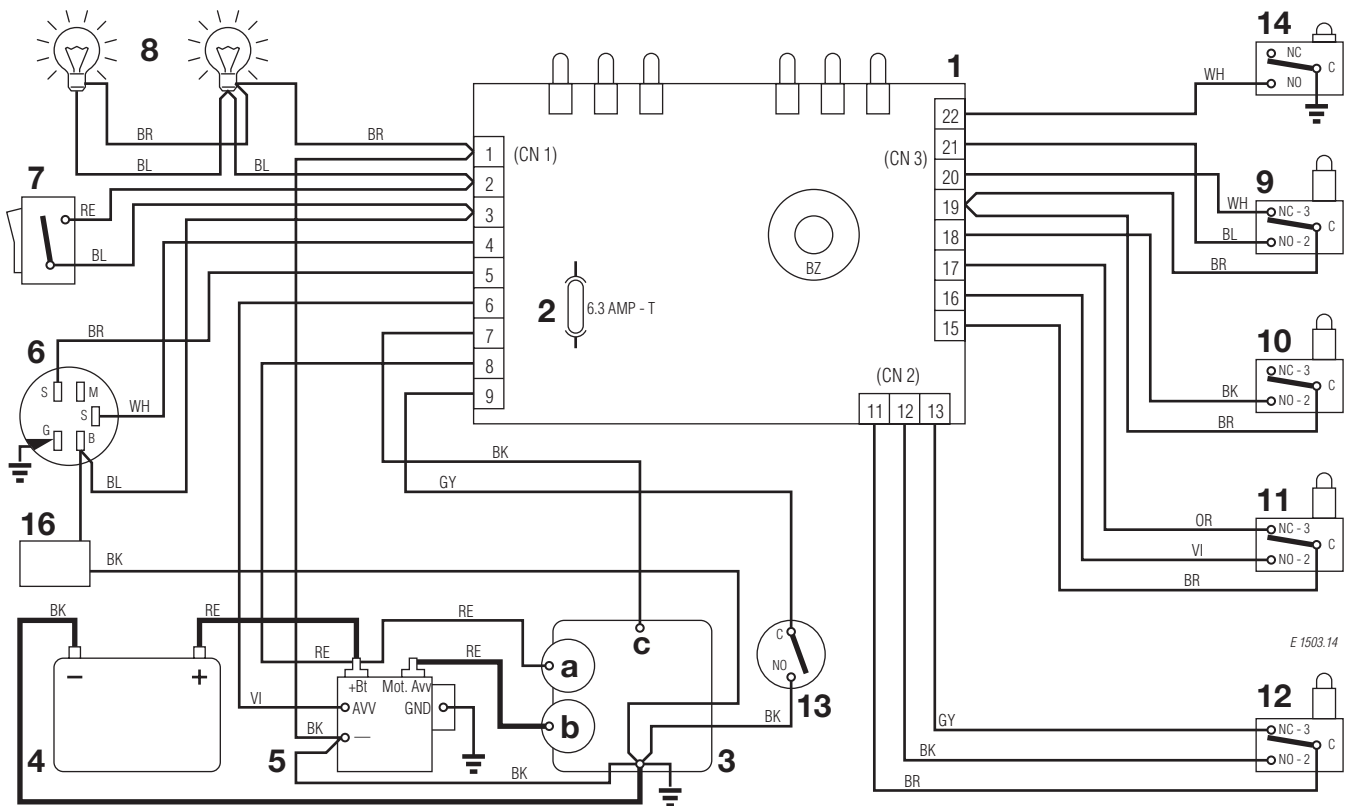

E 1503.14

1	SCHEDA CON BUZZER	ELECTRONIC CARD WITH BUZZER	CARTE ELECTRONIQUE AVEC BUZZER	ELECTRONISCHE KARTE MIT BUZZER
2	FUSIBILE 6,3 Amp. T	FUSE 6,3 Amp. T	FUSIBLE 6,3 Amp. T	SICHERUNG 6,3 Amp. T
3	MOTORE	ENGINE	MOTEUR	MOTOR
3a	Generatore	Generator	Genérateur	Generator
3b	Motorino avviamento	Starter	Demarreur	Anlasser
3c	Stop motore	Engine stop	Calage du moteur	Motor abstellung
4	BATTERIA	BATTERY	BATTERIE	BATTERIE
5	RELE AVVIAMENTO	STARTER RELAY	RELAIS DE DEMARRAGE	ANLASSER RELAIS
6	INTERRUTTORE A CHIAVE	ELECTROLOCK	INTERRUPTEUR D'ALLUMAGE	SCHLÜSSELSCHALTER
7	INTERRUTTORE FARI	HEADLIGHT SWITCH	INTERRUPTEUR PHARES	LICHTSCHALTER
8	FARI	HEADLIGHT	PHARES	LICHT
9	MICROINTERRUTTORE LAME	BLADES MICRO SWITCH	MICRO INTERRUPTEUR LAMES	MESSER MIKROSCHALTER
10	MICROINTERRUTTORE FRENO	BRAKE MICRO SWITCH	MICRO INTERRUPTEUR FREIN	BREMSE MIKROSCHALTER
11	MICROINTERRUTTORE SEDILE	SEAT MICRO SWITCH	MICRO INTERRUPTEUR SIEGE	SITZMIKROSCHALTER
12	MICROINTERRUTTORE SACCO	GRASSCATCHER MICRO SWITCH	MICRO INTERRUPTEUR BAC	GRASFANGEINRICHTUNG MIKROSCHALTER
13	MICROINTERRUTTORE CAMBIO	GERARBOX MICROSWITCH	MICRO INT. BOÎTE DE VITESSE	ANTRIEB MICROSWITCH
14	MICROINTERRUTTORE SACCO PIENO	FULL GRASSCATCHER MICRO SWITCH	MICRO BAC PLEIN	VOLLKORB VORRICHTUNG
16	CONTAORE (TCP)	HOUR COUNTER (TCP)	COMPTE-HEURS (TCP)	BETRIEBESSTUNDENZÄHLER (TCP)

COLORI CAVI

BK	NERO
BL	BLU
BR	MARRONE
GY	GRIGIO
OR	ARANCIONE
RE	ROSSO
VI	VIOLA
YG	GIALLO/VERDE
WH	BIANCO

CABLE COLOURS

BLACK
BLUE
BROWN
GREY
ORANGE
RED
VIOLET
YELLOW/GREEN
WHITE

COULEUR CABLES

NOIR
BLEU
BRUN
GRIS
ORANGE
ROUGE
VIOLET
JAUNE/VERT
BLANC

KABEL FARBEN

SCHWARZ
BLAU
BRAUN
GRAU
ORANGE
ROT
VIOLETT
GELB/GRÜN
WEISS

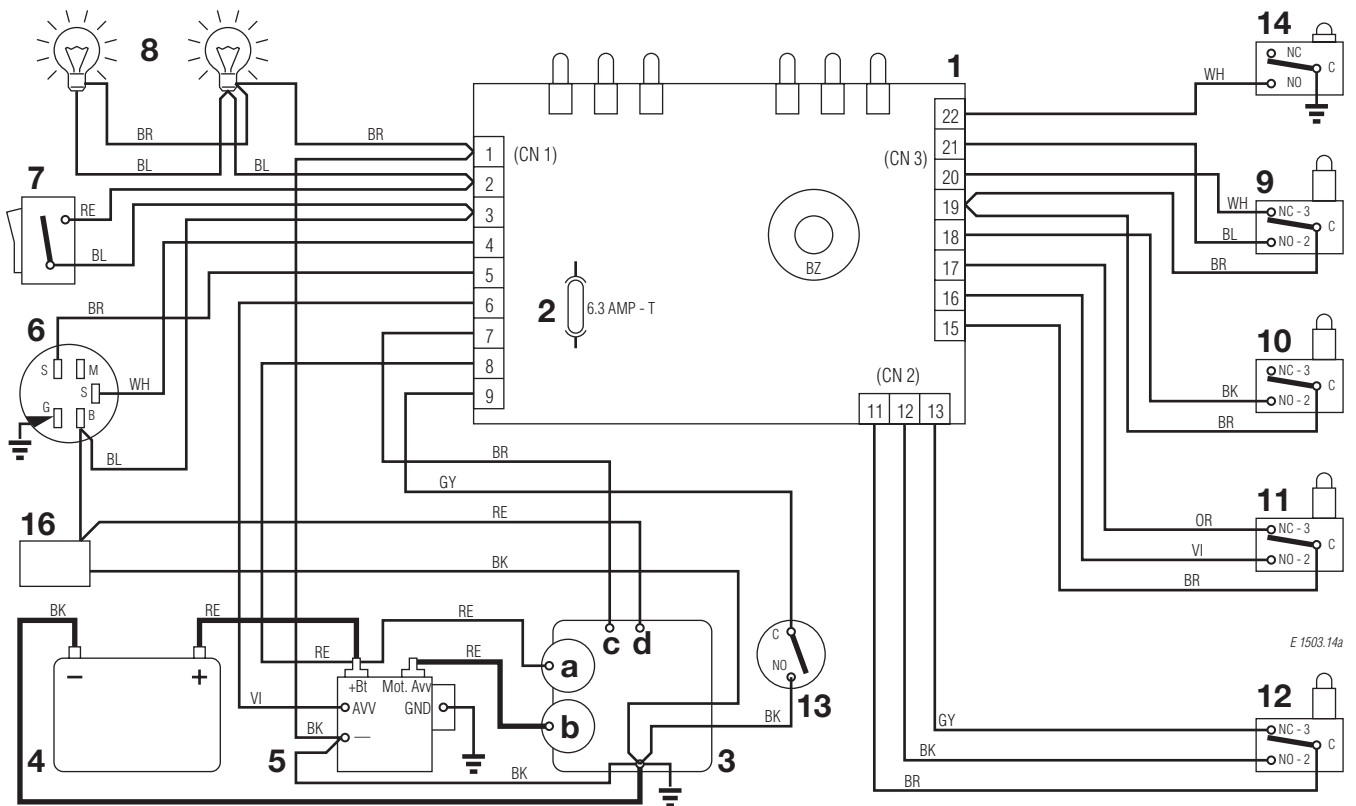

E 1503.14a

1	SCHEDA CON BUZZER	ELECTRONIC CARD WITH BUZZER	CARTE ELECTRONIQUE AVEC BUZZER	ELECTRONISCHE KARTE MIT BUZZER
2	FUSIBILE 6,3 Amp. T	FUSE 6.3 Amp. T	FUSIBLE 6,3 Amp. T	SICHERUNG 6,3 Amp. T
3	MOTORE	ENGINE	MOTEUR	MOTOR
3a	Generatore	Generator	Genérateur	Generator
3b	Motorino avviamento	Starter	Demarreur	Anlasser
3c	Stop motore	Engine stop	Calage du moteur	Motor abstellung
3d	Carburatore	Carburetor	Carburateur	Vergaser
4	BATTERIA	BATTERY	BATTERIE	BATTERIE
5	RELE AVVIAMENTO	STARTER RELAY	RELAIS DE DEMARRAGE	ANLASSER RELAIS
6	INTERRUTTORE A CHIAVE	ELECTROLOCK	INTERRUPTEUR D'ALLUMAGE	SCHLÜSSELSCHALTER
7	INTERRUTTORE FARI	HEADLIGHT SWITCH	INTERRUPTEUR PHARES	LICHTSCHALTER
8	FARI	HEADLIGHT	PHARES	LICHT
9	MICROINTERRUTTORE LAME	BLADES MICRO SWITCH	MICRO INTERRUPTEUR LAMES	MESSER MIKROSCHALTER
10	MICROINTERRUTTORE FRENO	BRAKE MICRO SWITCH	MICRO INTERRUPTEUR FREIN	BREMSE MIKROSCHALTER
11	MICROINTERRUTTORE SEDILE	SEAT MICRO SWITCH	MICRO INTERRUPTEUR SIEGE	SITZMIKROSCHALTER
12	MICROINTERRUTTORE SACCO	GRASSCATCHER MICRO SWITCH	MICRO INTERRUPTEUR BAC	GRASFANGENRICHUNG MIKROSCHALTER
13	MICROINTERRUTTORE CAMBIO	GERARBOX MICROSWITCH	MICRO INT. BOÎTE DE VITESSE	ANTRIEB MICROSWITCH
14	MICROINTERRUTTORE SACCO PIENO	FULL GRASSCATCHER MICRO SWITCH	MICRO BAC PLEIN	VOLLKORB VORRICHTUNG
16	CONTAORE (TCP)	HOUR COUNTER (TCP)	COMPTE-HEURS (TCP)	BETRIEBESSTUNDENZÄHLER (TCP)

COLORI CAVI

BK	NERO
BL	BLU
BR	MARRONE
GY	GRIGIO
OR	ARANCIONE
RE	ROSSO
VI	VIOLA
YG	GIALLO/VERDE
WH	BIANCO

CABLE COLOURS

BLACK
BLUE
BROWN
GREY
ORANGE
RED
VIOLET
YELLOW/GREEN
WHITE

COULEUR CABLES

NOIR
BLEU
BRUN
GRIS
ORANGE
ROUGE
VIOLET
JAUNE/VERT
BLANC

KABEL FARBEN

SCHWARZ
BLAU
BRAUN
GRAU
ORANGE
ROT
VIOLETT
GELB/GRÜN
WEISS

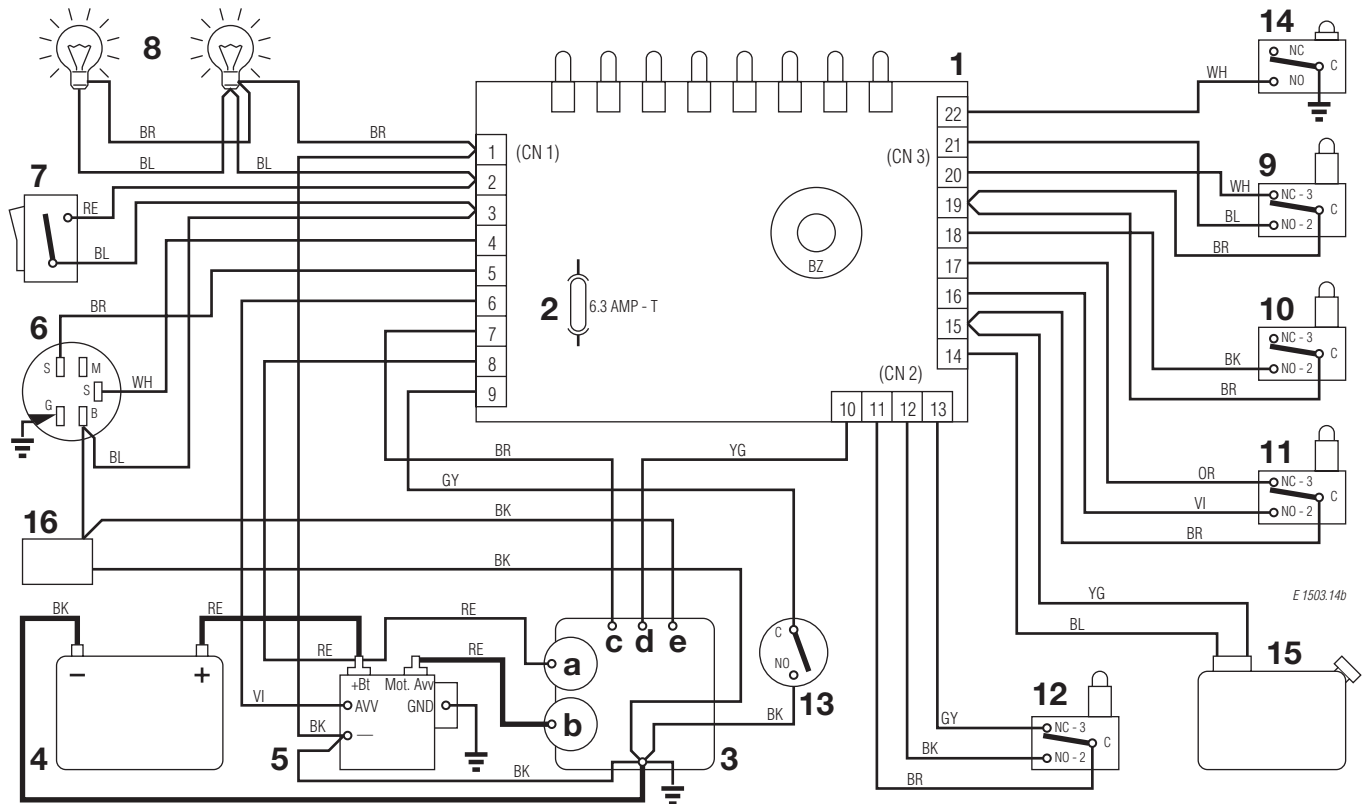

1	SCHEDA CON BUZZER	ELECTRONIC CARD WITH BUZZER	CARTE ELECTRONIQUE AVEC BUZZER	ELECTRONISCHE KARTE MIT BUZZER
2	FUSIBILE 6,3 Amp. T	FUSE 6.3 Amp. T	FUSIBLE 6,3 Amp. T	SICHERUNG 6,3 Amp. T
3	MOTORE	ENGINE	MOTEUR	MOTOR
3a	Generatore	Generator	Geneateur	Generator
3b	Motorino avviamento	Starter	Demarreur	Anlasser
3c	Stop motore	Engine stop	Calage du moteur	Motor abstellung
3d	Olio	Oil	Huile	Öl
3e	Carburatore	Carburetor	Carbureteur	Vergaser
4	BATTERIA	BATTERY	BATTERIE	BATTERIE
5	RELE AVVIAMENTO	STARTER RELAY	RELAIS DE DEMARRAGE	ANLASSER RELAIS
6	INTERRUTTORE A CHIAVE	ELECTROLOCK	INTERRUPTEUR D'ALLUMAGE	SCHLÜSSELSCHALTER
7	INTERRUTTORE FARI	HEADLIGHT SWITCH	INTERRUPTEUR PHARES	LICHTSCHALTER
8	FARI	HEADLIGHT	PHARES	LICHT
9	MICROINTERRUTTORE LAME	BLADES MICRO SWITCH	MICRO INTERRUPTEUR LAMES	MESSER MIKROSCHALTER
10	MICROINTERRUTTORE FRENO	BRAKE MICRO SWITCH	MICRO INTERRUPTEUR FREIN	BREMSE MIKROSCHALTER
11	MICROINTERRUTTORE SEDILE	SEAT MICRO SWITCH	MICRO INTERRUPTEUR SIEGE	SITZMIKROSCHALTER
12	MICROINTERRUTTORE SACCO	GRASSCATCHER MICRO SWITCH	MICRO INTERRUPTEUR BAC	GRASFANGEINRICHTUNG MIKROSCHALTER
13	MICROINTERRUTTORE CAMBIO	GERARBOX MICROSWITCH	MICRO INT. BOÎTE DE VITESSE	ANTRIEB MICROSWITCH
14	MICROINTERRUTTORE SACCO PIENO	FULL GRASSCATCHER MICRO SWITCH	MICRO BAC PLEIN	VOLLKORB VORRICHTUNG
15	SERBATOIO	TANK	RESERVIOR	TANK
16	CONTAORE (TCP)	HOUR COUNTER (TCP)	COMPTE-HEURS (TCP)	BETRIEBESSTUNDENZÄHLER (TCP)

COLORI CAVI

BK	NERO
BL	BLU
BR	MARRONE
GY	GRIGIO
OR	ARANCIONE
RE	ROSSO
VI	VIOLA
YG	GIALLO/VERDE
WH	BIANCO

CABLE COLOURS

BLACK
BLUE
BROWN
GREY
ORANGE
RED
VIOLET
YELLOW/GREEN
WHITE

COULEUR CABLES

NOIR
BLEU
BRUN
GRIS
ORANGE
ROUGE
VIOLET
JAUNE/VERT
BLANC

KABEL FARBEN

SCHWARZ
BLAU
BRAUN
GRAU
ORANGE
ROT
VIOLETT
GELB/GRÜN
WEISS