

MODEL	SE1200/SE1600 Shredder
PRODUCT NO.	9646505; 9646504

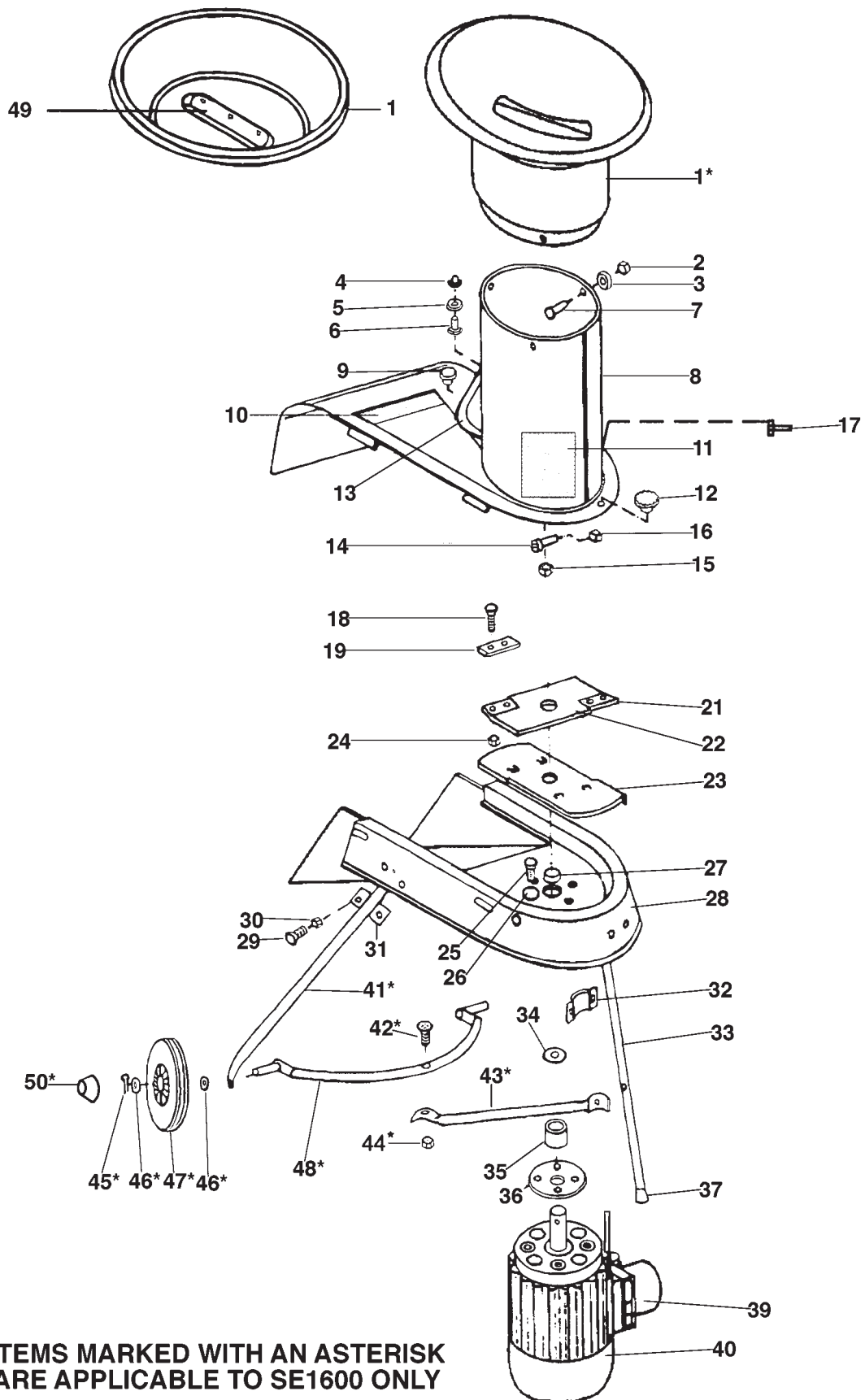

**\* ITEMS MARKED WITH AN ASTERISK ARE APPLICABLE TO SE1600 ONLY**

MODEL	SE1200/SE1600 Shredder
PRODUCT NO.	9646505; 9646504



KEY	PART NUMBER	DESCRIPTION	QTY
01	5195126-00/7	FUNNEL	1 SE1200
	5195127-00/5	FUNNEL	1 SE1600
02	5195128-00/3	NUT	3
03	5195129-00/1	WASHER	3
04	5195130-00/9	CAP NUT	2
05	5195131-00/7	WASHER	2
06	5195132-00/5	SCREW	2
07	5195133-00/3	SCREW	3
08	5195134-00/1	UPPER HOUSING	1
09	5195135-00/8	KNURLED SCREW	1
10	5195136-00/6	LABEL	1 SE1200
	5195137-00/4	LABEL	1 SE1600
11	5195138-00/2	LABEL,WARNING	1
12	5195139-00/0	STAR GRIP NUT	1
13	5195140-00/8	HANDLE	1
14	5195141-00/6	CAP SCREW	2
15	5195142-00/4	NUT,L/H	1
16	5195143-00/2	NUT,SELFLOCK	2
17	5195182-00/0	DOWEL/KNOB RETAINER	1
18	5195145-00/7	SOCKET SCREW	4
19	5195178-00/8	BLADE KIT	1
21	5195148-00/1	CUTTING BEAM C/W BLADES	1
22	5195149-00/9	CUTTING BEAM	1
23	5195150-00/7	CLEARING/EJECTION BEAM	1
24	5195151-00/5	NUT,SELFLOCK	4
25	5195152-00/3	SCREW	4
26	5195153-00/1	SPRING RING	4
27	5195154-00/9	V-RING	1
28	5195155-00/6	HOUSING TROUGH COMPLETE	1
29	5195156-00/4	SCREW	6
30	5195151-00/5	NUT,SELFLOCK	6
31	5195158-00/0	PIPE CLAMP - STRAIGHT	2
32	5195159-00/8	PIPE CLAMP - BENT	1
33	5195160-00/6	STAND FOOT	3 SE1200
	5195160-00/6	STAND FOOT	1 SE1600
34	5195161-00/4	SHIM RING -20X28X0.5	1
	5195144-00/0	SHIM RING -20X28X1	1
	5195147-00/3	SHIM RING -20X28X2	1
35	5195162-00/2	SPACER PIPE	1
36	5195163-00/0	FLANGE	1
37	5195164-00/8	PLUG-ON CAP	3 SE1200
	5195164-00/8	PLUG-ON CAP	1 SE1600
38	5195173-00/9	MAINS CABLE	1 (Not illustrated)
39	5195166-00/3	SWITCH ASSY	1 SE1200
	5195167-00/1	SWITCH ASSY	1 SE1600
40	5195168-00/9	MOTOR 1200 watt	1 SE1200
	5195169-00/7	MOTOR 1600 watt	1 SE1600
41	5195170-00/5	AXLE SUPPORT	1 SE1600
42	5195171-00/3	SCREW	2 SE1600
43	5195172-00/1	CROSS BAR	1 SE1600
44	5195151-00/5	NUT,SELFLOCK	2 SE1600
45	5195174-00/7	SPLIT PIN	2 SE1600
46	5195175-00/4	WASHER	4 SE1600
47	5195176-00/2	WHEEL	2 SE1600
48	5195177-00/0	AXLE COMPLETE	1 SE1600
49	5195179-00/6	SPLASH RETENTION	1 SE1600
	5195180-00/4	SPLASH RETENTION	1 SE1200
50	5195121-00/2	HUB CAP	1 SE1600

#### PRODUCT APPLICATION

9646505 SE1200  
9646504 SE1600

WHERE NO APPLICATION DETAILS ARE SHOWN, PART APPLIES TO ALL COUNTRIES

A Austria; AUS Australia; B Belgium; CND Canada; CH Switzerland; D Germany; DK Denmark; E Spain; EI Eire; F France; GB Great Britain; I Italy; N Norway; NL Netherlands; NZ New Zealand; O/S Overseas; P Portugal; S Sweden; SF Finland; USA America; ZA South Africa