

# Flymo

MODEL	XE300
PRODUCT NO.	9633027, 9633028, 9633081

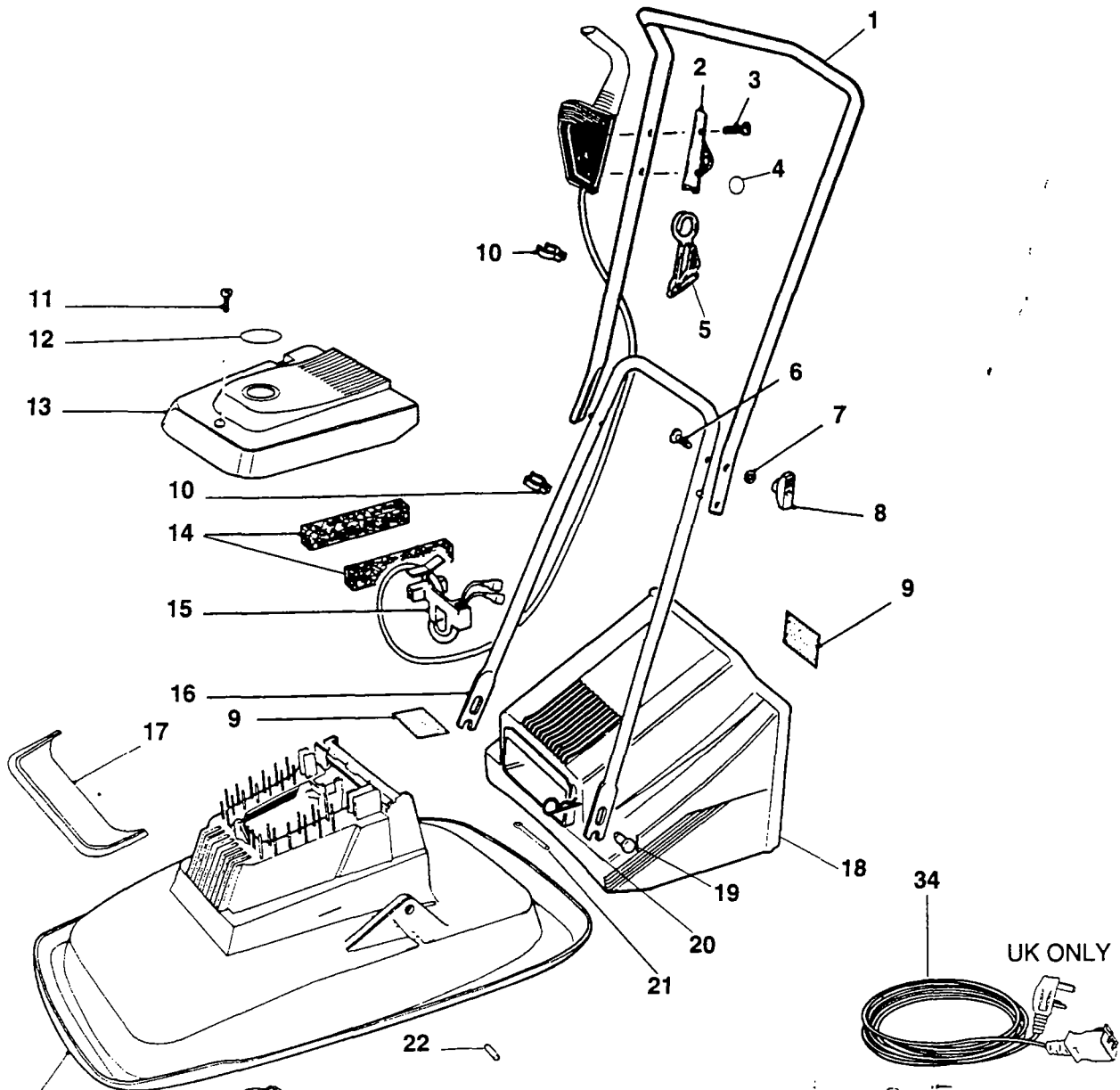

Plastic Cutting System  
 S12673A-00/2  
 S1A8257-00/14

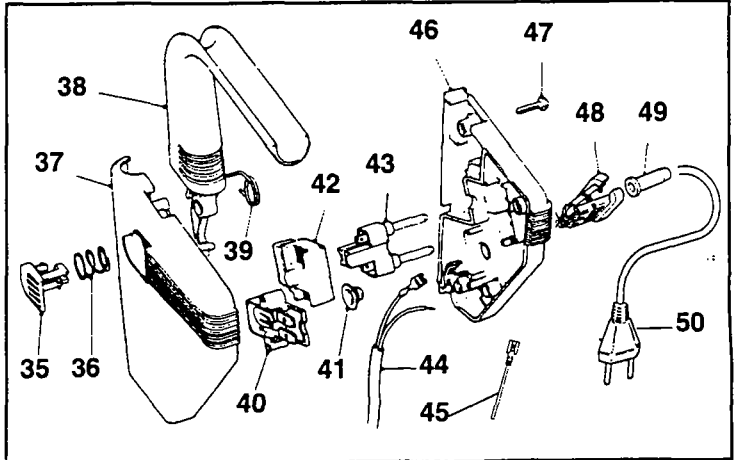

# Flymo

MODEL	XE300
PRODUCT NO.	9633027, 9633028, 9633081

KEY	PART NUMBER	DESCRIPTION	QTY
01	5126816-21/3	HANDLE/LABEL ASSY	1 GB.EI.
	5117667-01/3	HANDLE,UPPER	1 AUS.NZ.TH.N.DK.S.SF.A.B.D.F.NL.I.E.P.
02	5117659-01/0	RETAINER,SWITCHBOX	1 GB.EI.TH.
	5117657-01/4	RETAINER,SWITCHBOX	1 AUS.NZ.N.DK.S.SF.A.B.D.F.NL.I.E.P.
03	5146672-00/0	SCREW	2
04	5148886-00/4	SPLIT RING	1 N.DK.S.SF.
05	5138024-00/4	CORD GUIDE	1 AUS.NZ.A.B.D.F.NL.I.E.P.
	5126240-01/8	CORD GUIDE	1 N.DK.S.SF.
06	5148672-00/8	HANDLE BOLT	2
07	5140266-00/7	WASHER	2
08	5137679-00/6	WING KNOB	2
09	5138319-00/8	LABEL,WARNING	1
10	5137750-00/5	CLIP CABLE	2
11	5146736-00/3	SCREW	5
12	5137855-01/0	LABEL,AUTOSTOP	1
13	5126821-10/6	COVER ASSY	1 GB.EI.
	5126821-12/2	COVER ASSY	1 AUS.NZ.TH.N.DK.S.SF.A.B.D.F.NL.I.E.P.
14	5137638-00/2	FILTER	2
15	5126741-00/7	CLAMP,PLASTIC	1
16	5117690-01/5	HANDLE,LOWER	1
17	5126885-01/0	LABEL,FLYMO	1
18	5117079-06/0	GRASSBOX ASSY	1
19	5140092-03/1	PIVOT PIN	2
20	5140423-00/4	PIN,RETAINING	2 GB.EI.TH.N.DK.S.SF.A.B.D.F.NL.I.E.P.
21	5141424-01/9	SPLIT PIN	2 AUS.NZ.
22	5147594-00/5	PIN	2
23	5126819-01/9	HOOD 30CM	1
24	5150007-01/0	MOTOR - 240V	1 GB.EI.AUS.NZ Use with product No: 9633027 ONLY
	5150007-02/8	MOTOR - 220V	1 TH.N.DK.S.SF.A.B.D.F.NL.I.E.P. Use with product No: 9633028 ONLY
	5150007-00/2	MOTOR - 230V	1 GB.EI.TH.N.DK.S.SF.A.B.D.F.NL.I.E.P.
25	5106491-00/3	MOTOR MOUNTING PLATE	1
26	5148122-01/2	SCREW	4
27	5126764-00/9	INSERT,IMPELLER	1
28	5116967-10/9	IMPELLER	1
29	5138110-01/9	BLADE SPACER,PEGGED	3
30	5126439-00/8	BLADE 30CM	1
31	5148259-00/4	WASHER,ANTI FRICTION	1
32	5126682-00/3	SPANNER/SCRAPER	1
33	5137608-00/5	BLADE BOLT ASSY	1
34	5127250-03/2	LEAD	1 GB..EI.
	5126968-00/6	LEAD	1 AUS.NZ
	5127090-01/6	LEAD	1 TH.
35	5127008-00/0	LOCK OFF	1
36	5148658-00/7	SPRING,LOCK OFF	1
37	5106539-01/7	SWITCHBOX UPPER	1
38	5106481-01/2	LEVER	1
39	5148657-00/9	SPRING,TORSION	1
40	5127255-01/5	THERMAL CUT-OUT	1
41	5149024-00/1	CUT-OUT COVER	1
42	5137685-00/3	SWITCH	1 GB.EI.TH.
	5137786-00/9	SWITCH	1 AUS.NZ.N.DK.S.SF.A.B.D.F.NL.I.E.P.
43	5137886-00/1	PIN RETAINER	1 GB.EI.TH.
	5148784-00/1	PIN RETAINER	1 N.DK.S.SF.A.B.D.F.NL.I.E.P.
44	5148814-12/1	LEAD ASSY	1 GB.EI.AUS.NZ.TH.N.DK.S.SF.
	5148814-17/0	LEAD ASSY	1 A.B.D.F.NL.I.E.P.
45	5148773-00/4	LEAD,INTERNAL	1
46	5106538-01/9	SWITCHBOX LOWER	1 GB.EI.AUS.NZ.TH
	5106540-01/5	SWITCHBOX LOWER	1 N.DK.S.SF.A.B.D.F.NL.I.E.P.
47	5146672-00/0	SCREW	4
48	5117528-00/9	CABLE RETAINER	1 AUS.NZ
49	5148741-00/1	PROTECTION SLEEVE	1 AUS.NZ
50	5148280-04/2	CONNECTING LEAD	1 AUS.NZ

#### PRODUCT APPLICATION

9633027-01	GB.EI.	9633028-27	N.DK.S.SF.	9633081-22	CH.
9633027-99	AUS.NZ.	9633028-85	A.B.D.F.NL.I.E.P.	9633081-27	N.DK.S.SF.
9633028-16	TH.	9633081-01	GB.EI.	9633081-85	A.B.D.F.NL.I.E.P.

WHERE NO APPLICATION DETAILS ARE SHOWN, PART APPLIES TO ALL COUNTRIES

A Austria; AUS Australia; B Belgium; CND Canada; CH Switzerland; D Germany; DK Denmark; E Spain; EI Eire; F France; GB Great Britain; I Italy; N Norway; NL Netherlands; NZ New Zealand; O/S Overseas; P Portugal; S Sweden; SF Finland; USA America; ZA South Africa