

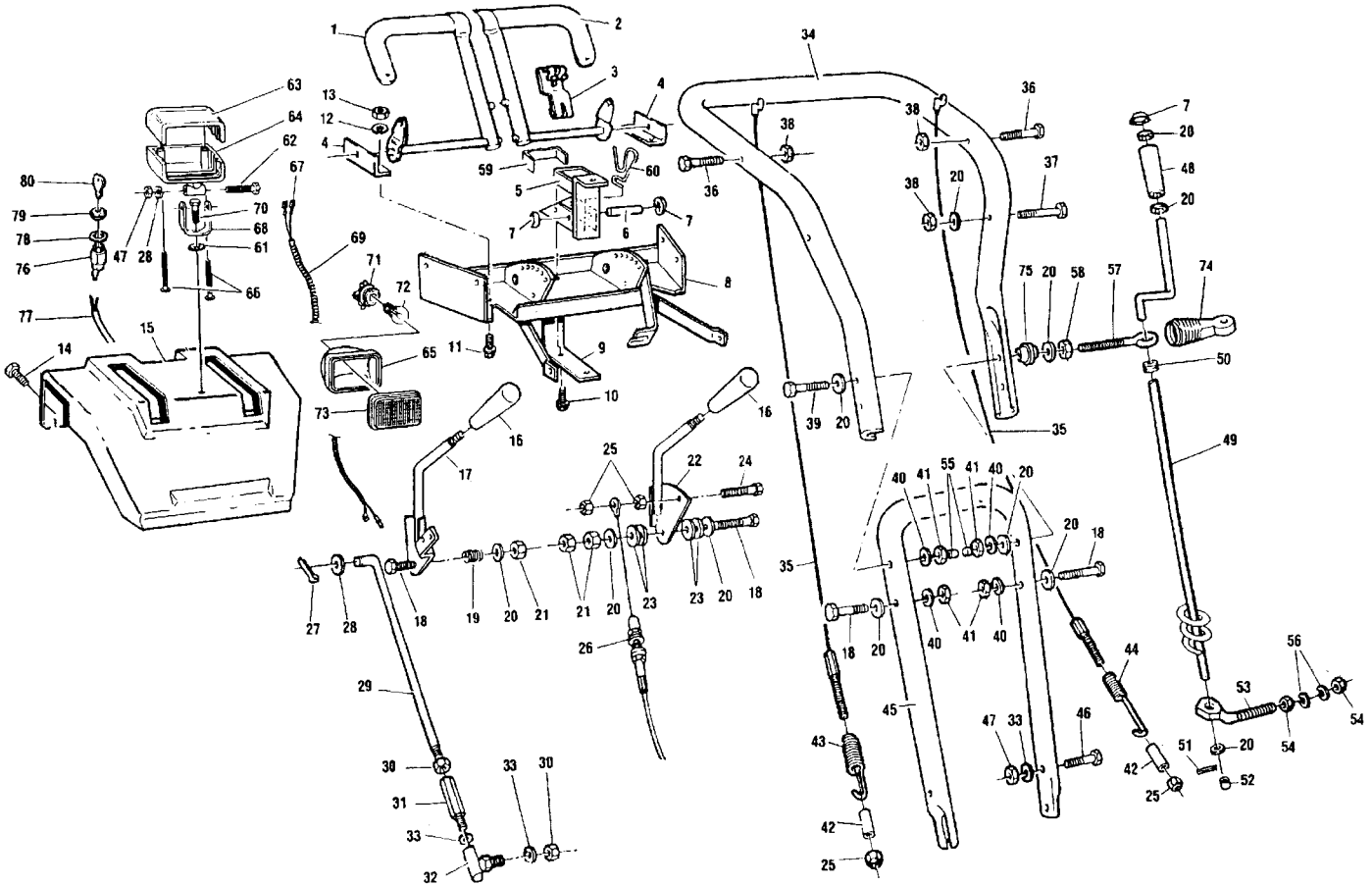

Prod.no: 968 87 02-10
 Engine: Tecumseh
 HMSK 100-159243 T

SPAREPARTS

107 26 54-61



Ref. No.	Part.No.	Description	Ref. No.	Part.No.	Description	Ref. No.	Part.No.	Description
1	533 58 03-19	Clutch handle R.H.	28	515 47 10-71	5/16 flat washer	55	515 40 72-89	Plastic stop
2	533 58 03-18	Clutch handle L.H.	29	515 40 64-70	Rod speed control	56	515 40 70-59	1/2 lockwasher
3	515 40 84-17	Cam lock	30	515 47 10-42	5/16-24 hex nut	57	515 47 14-57	3/8 eye bolt
4	515 40 64-48	Clutch handle bracket	31	515 40 63-52	Adaptor	58	515 47 10-45	3/8-16 jam nut
5	515 57 86-54	Bracket light	32	515 45 07-82	Ball joint	59	515 57 86-57	Rubber pad
6	533 58 46-73	Pin latch	33	515 47 10-60	5/16 lockwasher	60	515 57 86-53	Spring cam assist
7	515 47 36-64	3/8 cap retainer	34	533 00 71-14	Upper handle	61	533 71 01-61	5/16 external tooth lockwasher
8	533 00 64-42	Console bracket remote	35	515 40 15-80	Clutch cable	62	515 40 02-35	5/16-18 x 2 bolt
9	515 40 64-68	Bracket console support	36	515 47 09-89	5/16-18 x 1-1/2 bolt	63	533 58 34-90	Upper housing headlight
10	515 47 09-82	5/16-18 x 1/2 self tapping screw	37	515 47 09-90	5/16-18 x 1-3/4 bolt	64	533 58 34-91	Lower housing headlight
11	515 47 09-67	1/4-20 x 1/2 bolt	38	515 47 13-91	5/16-18 locknut	65	533 57 92-68	Housing, light
12	515 47 10-59	1/4 lockwasher	39	515 40 72-88	3/8-16 x 3 bolt	66	533 58 34-05	10 x 1-3/4 screw
13	515 47 10-34	1/4-20 hex nut	40	515 47 10-62	3/8 lockwasher	67	533 30 77-67	Wiring harness, light
14	515 47 09-78	1/4-20 x 1/2 self tapping screw	41	515 47 10-44	3/8-16 hex nut	68	515 40 40-30	Bracket mounting, light
15	533 58 56-71	Console remote	42	515 40 65-44	Spacer	69	533 00 66-36	Wire conduit
16	533 30 47-28	Control knob	43	515 40 16-73	Spring auger clutch	70	533 00 41-60	5/16-18 x 1-3/4 carriage bolt
17	515 40 64-44	Speed control lever	44	515 40 16-71	Spring drive clutch	71	533 57 92-69	Socket, ASM
18	515 40 40-58	3/8-16 x 1-3/4 bolt	45	533 00 55-44	Lower handle	72	533 58 15-76	Bulb, headlight
19	515 45 07-86	Spring	46	515 47 09-85	5/16-18 x 3/4 bolt	73	533 57 92-66	Lens, flood, clear
20	515 47 10-72	3/8 flat washer	47	515 47 10-37	5/16-18 hex nut	74	533 30 81-45	Boot
21	515 47 10-46	3/8-16 locknut	48	533 30 73-99	Handle crank	75	533 30 93-44	Adaptor boot
22	515 40 64-38	Deflector lever remote	49	533 08 51-92	Crank	76	515 43 03-13	Switch On/Off
23	515 40 40-51	Spring washer	50	515 40 01-48	Grommett	77	515 45 11-55	Wire harness
24	515 40 40-58	1/4-20 x 1 bolt	51	515 47 10-71	3/32 x 3/4 cotter pin	78	515 43 03-14	5/8 lockwasher
25	515 47 10-35	1/4 x 20 nylock	52	515 40 01-04	Plastic cap	79	515 43 03-15	5/8-32 nut
26	515 40 40-52	Remote chute cable	53	515 40 70-55	Rod chute control	80	515 43 03-16	Key
27	515 47 10-81	3/32 x 3/4 cotter pin	54	515 40 70-58	1/2-20 jam nut			

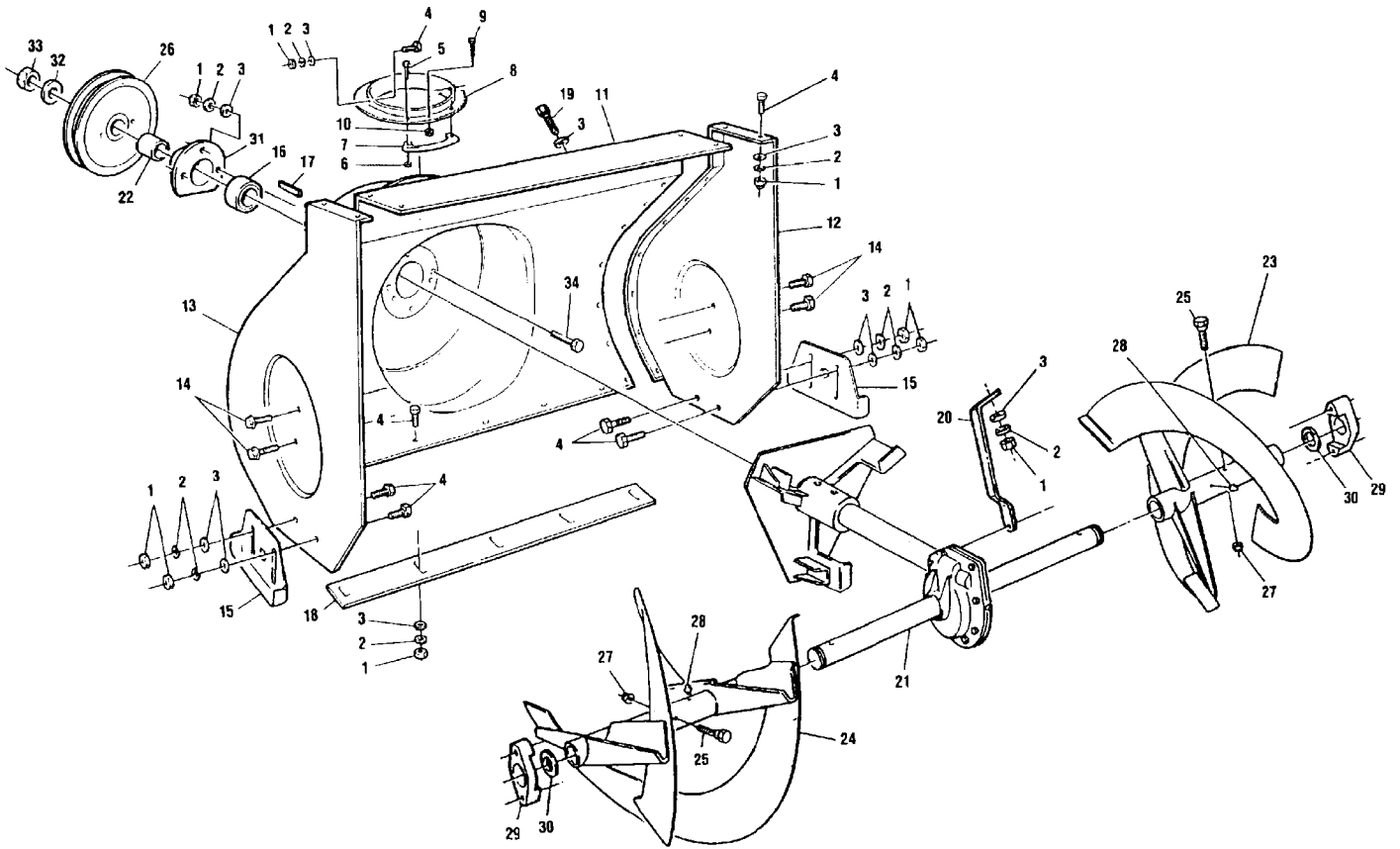

Ref. No.	Part.No.	Description	Ref. No.	Part.No.	Description	Ref. No.	Part.No.	Description
1	515 47 10-37	5/16-18 hex nut	13	533 00 69-21	Side plate R.H.	25	515 57 86-47	Shear bolt
2	515 47 10-60	5/16 lockwasher	14	515 47 09-84	5/16-18 x 3/4 self tapping screw	26	533 58 31-46	Auger pulley 8.4"
3	515 47 10-71	5/16 flatwasher	15	533 00 08-73	Height adjustor	27	515 47 13-91	5/16-18 locknut
4	515 47 09-93	5/16-18 x 3/4 carriage bolt	16	533 58 07-81	Bearing	28	515 41 01-04	Grease fitting
5	515 47 10-32	8-32 x 1/2 bolt	17	533 07 13-71	3/16 key	29	515 45 37-57	Bushing auger shaft
6	533 07 10-57	8-32 nylock	18	533 00 69-25	33" scraper bar	30	515 45 07-48	Washer
7	515 48 51-13	Retainer	19	515 47 09-86	5/16-18 x 1 bolt	31	533 58 29-60	Retainer, bearing
8	533 01 14-97	Flange	20	515 40 55-24	Gear box brace	32	515 47 10-74	1/2 washer
9	515 47 09-69	1/4-20 x 1 bolt	21	533 58 33-32	33" gear box assembly	33	533 00 52-51	1/2-20 locknut
10	515 47 10-35	1/4-20 locknut	22	533 58 32-26	Space, impeller	34	515 47 09-83	5/16-18 x 5/8 bolt
11	533 58 31-85	Auger housing 33"	23	533 00 28-04	33" serrater auger L.H.			
12	533 00 69-22	Side plate L.H.	24	533 00 28-07	33" serrater auger R.H.			

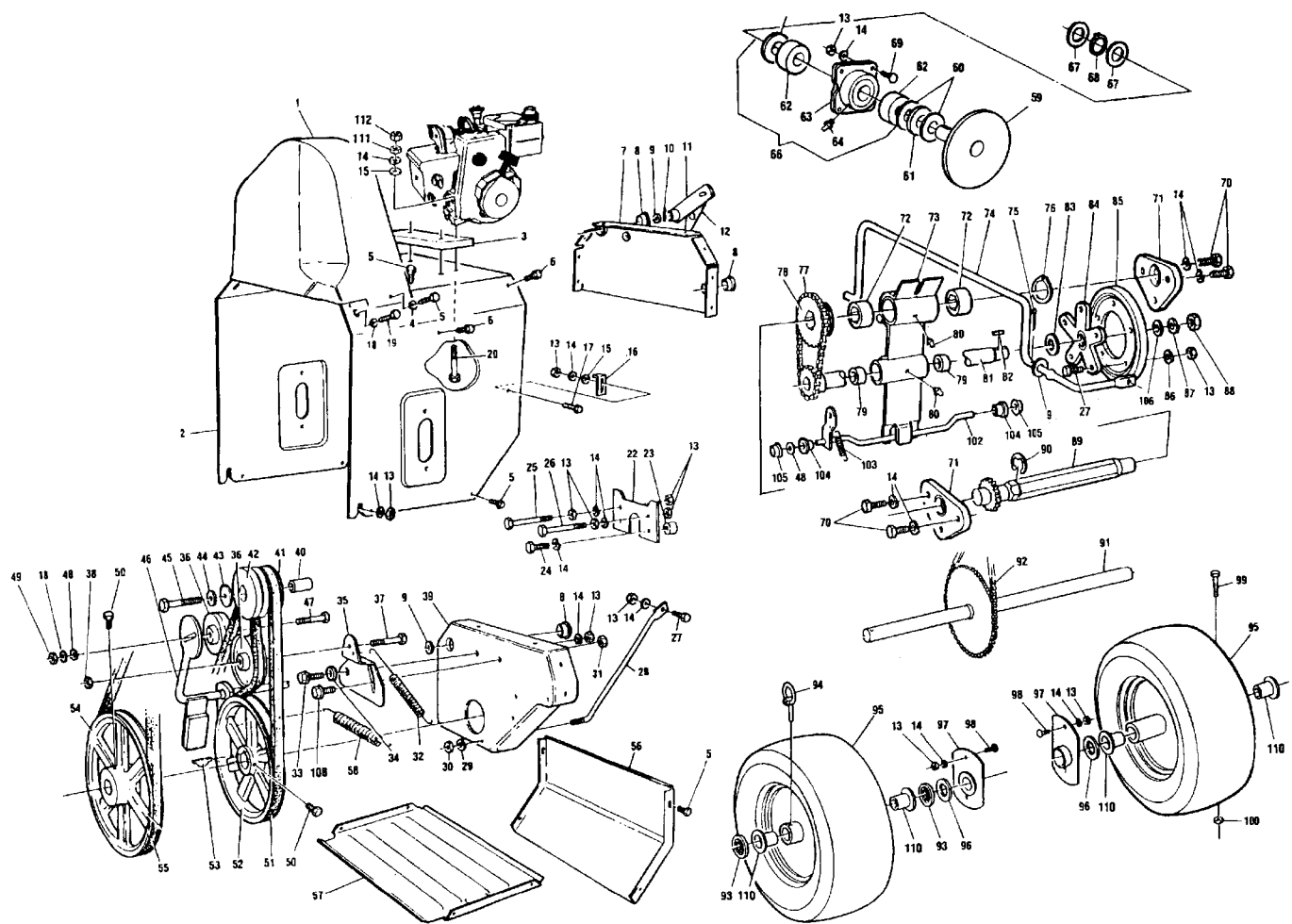

Ref. No.	Part.No.	Description	Ref. No.	Part.No.	Description	Ref. No.	Part.No.	Description
1	515 40 64-54	Belt cover	39	515 45 36-96	Spindle plate	76	515 45 07-07	Retainer
2	533 05 36-91	Motor mount frame	40	533 58 17-31	Engine pulley spacer 3/4"	77	515 40 58-93	Chain
3	533 08 51-89	Engine riser	41	515 45 37-14	Pulley traction drive 3/4"	78	515 40 58-99	Drive sprocket
4	515 47 10-67	1/4 flat washer	42	515 45 37-15	Pulley auger drive 3/4"	79	515 45 07-00	Bearing clutch
5	515 47 09-78	1/4-20 x 1/2 self tapping screw	43	515 45 06-77	Washer	80	515 43 04-40	Grease fitting
6	515 47 09-82	5/16-18 x 1/2 self tapping screw	44	515 47 10-63	3/8 lockwasher	81	533 00 65-49	Shaft gear assembly
7	533 08 54-06	End plate	45	515 47 11-28	3/8-24 x 1-1/4 bolt	82	515 47 12-03	1/8 key
8	515 45 37-03	Plastic bushing	46	515 40 01-69	Auger clutch rod	83	515 45 07-04	Washer
9	515 47 10-74	1/2 flat washer	47	515 47 10-10	3/8-16 x 1-1/2 bolt	84	515 40 58-92	Hub friction wheel
10	515 47 38-01	5/32 x 7/8 roll pin	48	515 47 10-72	3/8 flat washer	85	515 40 58-98	Friction wheel
11	515 48 54-92	Lever auger clutch	49	515 47 10-45	3/8-16 jam nut	86	515 47 10-61	5/16 external tooth lockwasher
12	515 48 54-94	Lever clutch cable	50	515 57 74-00	5/16-18 x 5/8 bolt	87	515 47 10-62	3/8 lockwasher
13	515 47 10-37	5/16-18 hex nut	51	515 45 14-58	Belt traction drive	88	515 47 10-48	3/8-24 hex nut
14	515 47 10-60	5/16 lockwasher	52	515 45 07-94	Traction pulley 7"	89	515 40 40-62	Hex shaft
15	515 47 10-71	5/16 flat washer	53	515 45 07-95	3/16 key	90	515 45 08-84	Retainer
16	515 45 37-13	Bracket clutch adjustment	54	533 58 31-46	Auger pulley 8.4"	91	515 40 61-77	Axle
17	515 47 09-93	5/16-13 x 3/4 carriage bolt	55	515 45 12-24	Belt auger drive	92	515 40 31-81	Chain
18	515 47 10-62	3/8 lockwasher	56	533 05 07-76	Rear panel	93	515 40 02-39	Retainer
19	515 47 10-12	3/8-16 x 1 self tapping screw	57	533 05 07-44	Bottom panel	94	515 47 38-42	Click pin
20	515 41 08-06	5/16-18 x 2-3/4 bolt	58	515 40 42-93	Spring auger brake	95	533 58 46-33	Wheel 16 x 6.50-8
22	515 48 51-87	Belt guide plate	59	515 48 52-14	Friction disc assembly	96	515 47 38-40	Washer
23	515 45 14-38	Spacer	60	515 45 06-83	Race thrust	97	515 40 59-54	Axle bracket
24	515 47 13-93	5/16-24 x 1 bolt	61	515 45 06-84	Needle bearing	98	515 47 09-93	5/16-18 x 3/4 carriage bolt
25	515 47 09-91	5/16-18 x 3 bolt	62	515 45 06-89	Needle bearing	99	515 57 70-15	1/4-20 x 1-1/2 bolt GR 5
26	533 57 85-61	Belt guide	63	515 45 06-90	Spindle housing	100	515 47 38-26	1/4-20 locknut
27	515 47 09-85	5/16-18 x 3/4 bolt	64	515 45 15-01	Grease fitting	102	515 48 54-21	Yoke drive
28	515 45 14-45	Rod spindle support	65	515 45 06-54	Seal	103	515 45 37-10	Spring clutch yoke return
29	515 47 10-59	1/4 lockwasher	66	515 48 50-95	Spindle housing	104	515 45 07-12	Bushing
30	515 47 10-34	1/4-20 hex nut	67	515 45 06-66	Race thrust	105	515 40 17-95	3/8 cap retainer
31	515 47 13-91	5/16-18 locknut	68	515 45 06-88	3/4 ring retainer	106	515 40 40-51	Spring washer
32	515 45 14-47	Spring drive idler	69	515 47 09-93	5/16-18 x 3/4 carriage bolt	107	533 01 05-79	5/16-18 x 1 bolt GR 5
33	515 45 07-40	5/16-18 x 3/4 shoulder bolt	70	515 40 31-34	5/16-18 x 1/2 bolt	108	515 47 09-84	5/16-18 x 3/4 self tapping screw
34	515 47 10-73	7/16 flat washer	71	515 40 14-13	Drive bushing	109	533 57 85-59	5/16-18 x 5/8 GR 5 bolt
35	515 48 51-11	Idler bracket	72	515 45 07-05	Drive shaft hex bearing	110	515 57 85-72	Bushing wheel
36	515 45 14-48	3" idler pulley	73	515 48 52-04	Clutch plate	111	515 47 10-42	5/16-24 Hex nut
37	515 47 10-06	3/8-16 x 1-1/4 bolt	74	515 45 14-46	Yoke speed	112	533 47 10-43	5/16-24 Nylock nut
38	515 40 05-90	3/8-16 jam nut	75	515 47 10-81	3/32 x 3/4 cotter pin			

Ref. No.	Part.No.	Description
1	533 00 41-38	Chute deflector remote
2	515 40 35-19	Spring
3	515 47 11-47	5/16-18 x 3/4 hand head slotted bolt
4	515 47 10-38	5/16-18 locknut
5	515 40 67-11	Plastic washer
6	533 00 68-89	Chute extension remote
7	515 40 41-73	Bracket cable
8	515 40 31-34	5/16-18 x 1/2 bolt
9	515 47 13-91	5/16-18 locknut
10	515 47 10-21	10-24 x 3/8 bolt
11	533 07 10-55	10-24 locknut
12	515 47 09-69	1/4-20 x 1 bolt
13	515 47 10-35	1/4 x 20 locknut
14	515 40 41-35	Remote wire form
15	515 41 08-10	5/16-24 x 3" bolt
16	515 40 40-52	Remote cable

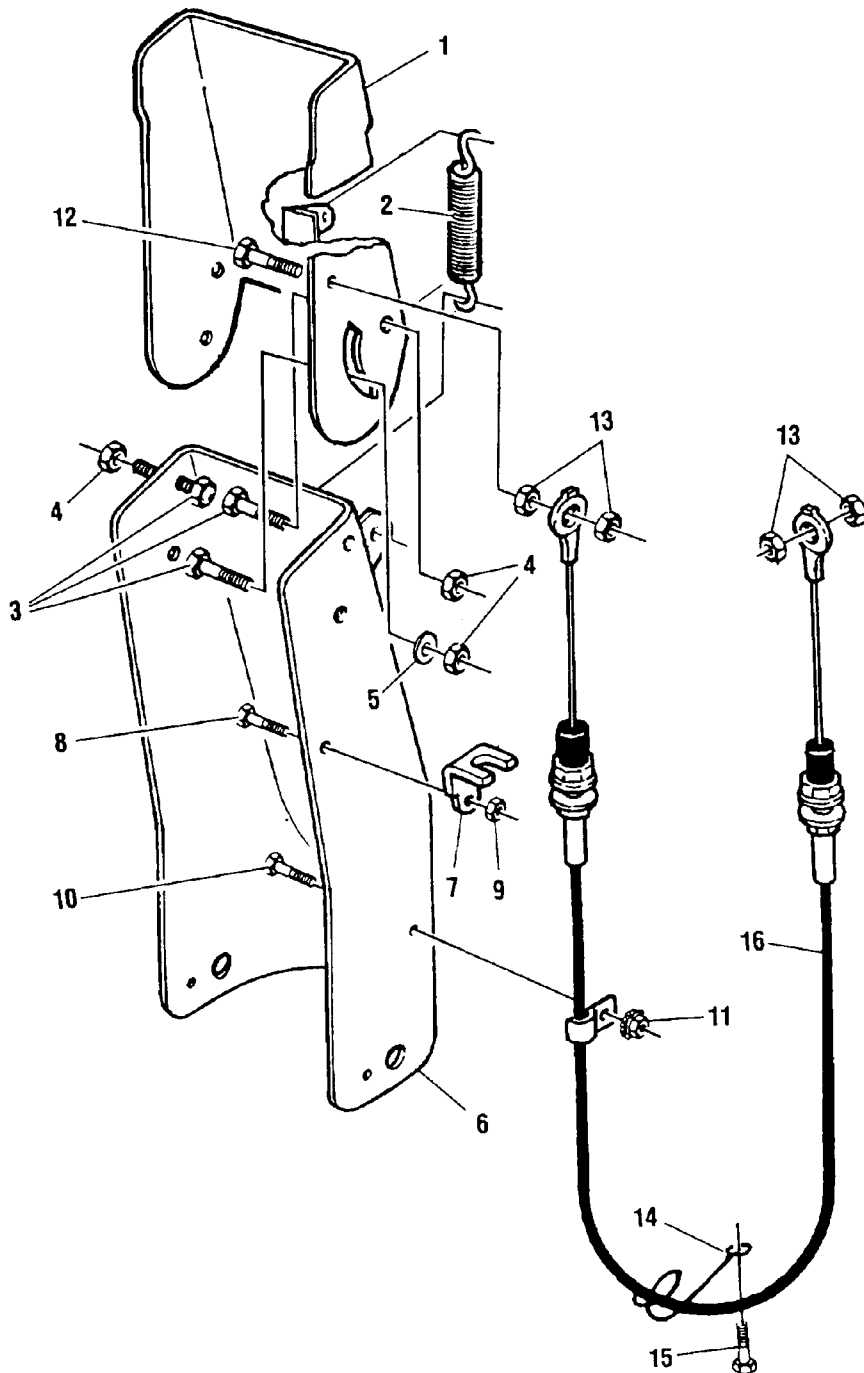

Ref. No.	Part.No.	Description
1	515 45 37-44	Seal
2	515 40 08-95	Housing L.H.
3	515 45 37-43	Bearing
4	515 40 08-98	Housing assembly L.H.
5	515 45 37-48	Race thrust
6	515 47 39-05	Key Woodruff #91
7	515 45 37-30	Worm gear
8	515 40 08-97	Gasket
9	515 40 08-99	Housing assembly R.H.
10	515 40 14-03	33" auger shaft
12	515 45 37-37	Ring quad
13	533 58 31-26	Bearing impeller shaft
14	533 07 13-71	3/16 key
15	515 45 06-84	Bearing needle
16	515 40 93-46	Race thrust
17	515 45 07-95	Key 3/16"
18	515 45 37-32	Worm
19	515 47 10-67	1/4 flat washer
20	515 47 38-26	1/4-20 locknut
21	515 45 37-31	Bearing impeller shaft
22	515 45 37-49	Grease plug
23	533 58 38-87	Impeller shaft
24	533 08 51-42	Impeller
25	515 40 08-96	Housing R.H.
26	515 47 13-93	5/16-24 x 1 bolt
27	515 47 11-00	5/16-24 flange locknut
28	515 47 38-39	1/4-20 x 2-1/4 bolt

