

shindaiwa®

ILLUSTRATED PARTS LIST

PIEZAS DE REPUESTO

LE RÉPERTOIRE DES PIÈCES ILLUSTRÉS

F-20

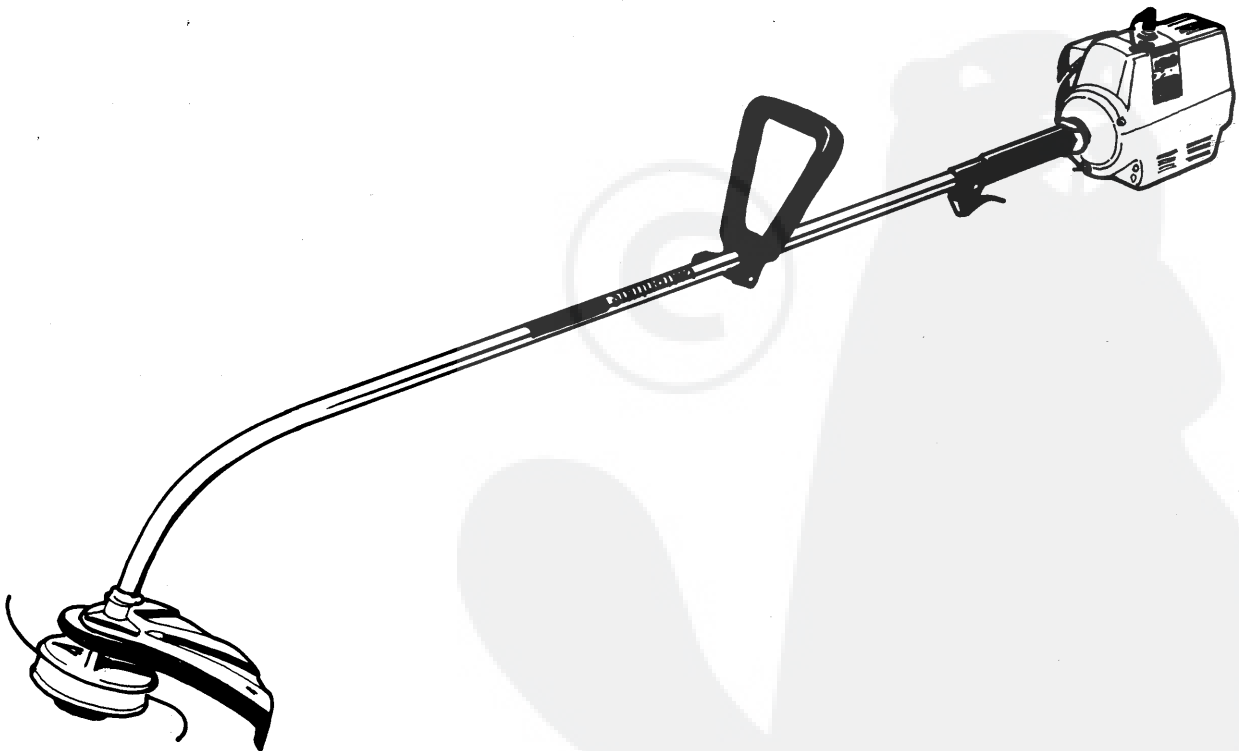

FOREWORD

This PARTS LIST covers all the parts for SHINDAIWA Model F-20.

RECOMMENDED QUANTITIES

1. Ranking

The following ranking such as A, B, C, and D is made in proportion to the part replacement frequency.

RANKING	DESCRIPTION	EXAMPLE
A	Parts, considered to be consumable or equivalent.	Filter
B	Parts, to be replaced at the time of disassembly and maintenance after one year's use.	Snap ring, Oil seal.
C	Parts, considered desirable to be replaced or sometimes to be replaced at the time of disassembly and maintenance.	Rubber parts, Bearing.
D	Parts, unnecessary for replacement except for breakage and missing	Crankcase

PROLOGO

Esta lista cubre los repuestos y herramientas originales del modelo SHINDAIWA F-20.

RECOMENDACIONES PARA INVENTARIO

1. Clasificación:

La siguiente clasificación: A, B, C y D ha sido preparada para ayudarle en determinar el número adecuado de piezas que deben mantenerse en inventario.

CLASIFICACION	DESCRIPCION	EJEMPLO
A	Piezas que se gastan bajo uso normal.	Resorte Filtro
B	Piezas que deben ser reemplazadas al hacer mantenimiento despues de un año de uso	Anillos Pistón
C	Piezas que pueden ser cambiadas al hacer mantenimiento ó cuando hay que desarmar la maquina	Cojinetes Boquillas
D	Piezas que deben ser reemplazadas cuando se dañan.	Carter del Motor

AVANT PROPOS

Ceci est le répertoire des pièces pour le modèle SHINDAIWA F-20.

QUANTITES RECOMMANDEES

1. Rang

Le classement suivant, tel que A, B, C, D, est établi en porportion de la fréquence de remplacement.

RANG	DESCRIPTION	EXEMPLE
A	Pièces considérées comme nécessitant leur remplacement pour usure normale.	Filtre
B	Pièces devant être remplacées lors d'un démontage ou pour maintenance après une année d'usage	Anneaux blocants, Joints d'étachéité
C	Pièces considérées comme devant être remplacées occasionnellement ou lors d'un démontage ou revisions.	Pièces de caoutchouc, Roulements.
D	Pièces ne nécessitant pas de remplacement autrement que par bris ou pertes	Carter de manivelle

Use the chart at right to find recommended quantities for inventory, based on number of units sold per year.

Use este cuadro para encontrar las cantidades recomendadas que deben mantenerse en inventario, en relación a la cantidad de unidades vendidas.

Utiliser la charte de droite pour établir les quantités recommandées pour stockage, basées sur la quantité d'unités vendues par année.

RANKING	Recommended parts inventory for Inventario recomendado para Recommandations pour inventaire							
	30 UNIT	50 UNIT	100 UNIT	200 UNIT	300 UNIT	500 UNIT	1000 UNIT	3000 UNIT
A	6	10	20	35	45	70	120	270
B	4	8	15	25	35	50	80	160
C	2	6	10	15	20	30	50	100
D	1	2	5	8	10	15	20	50

F-20
CYLINDER
CILINDRO
CYLINDRE

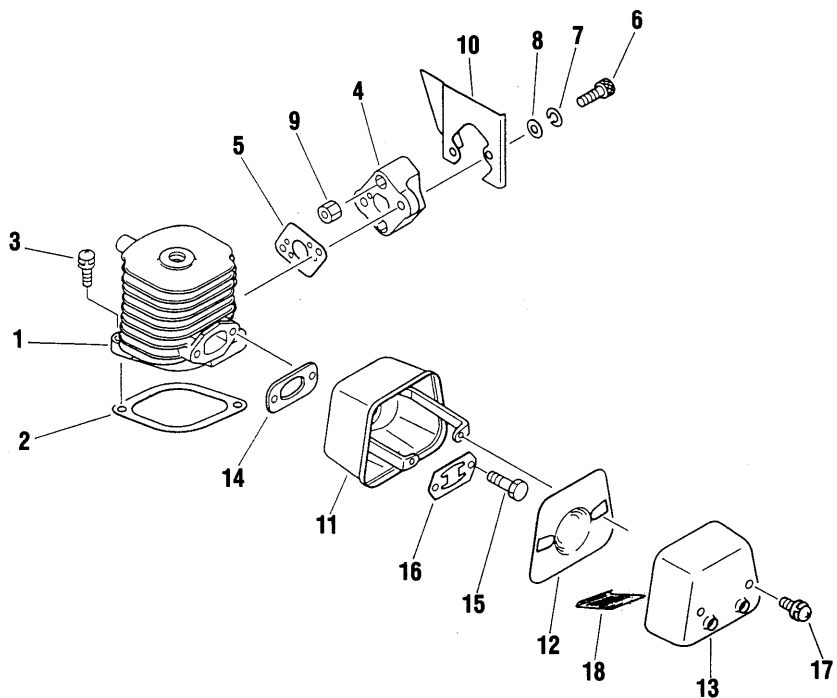

Index No. Indice	Part No. Pieza No. Numero	Part Name	Descripción	Nom de la pièce	Quant. Cant.	Serial No. Serie No.	Remarks Notas Note	Rank
1	70030-12110	CYLINDER	CILINDRO	CYLINDRE	1			D
2	70030-12120	GASKET	EMPAQUETADURA	JOINT	1			B
3	11022-05200	SCREW	TORNILLO	VIS	2			D
4	70030-12210	INSULATOR	AISLADOR	ISOLATEUR	1			C
5	70030-12220	GASKET	EMPAQUETADURA	JOINT	1			C
6	01020-05180	BOLT	PERNO	BOULON	2			D
7	01600-05131	SPRING WASHER	ARANDELA MUELLE	RONDELLE A RESSORT	2			D
8	01610-05080	WASHER	ARANDELA	RONDELLE	2			D
9	20011-12260	NUT	TUERCA	ECROU	2			D
10	70030-12230	AIR GUIDE	DEFLECTOR DE AIRE	DEFLECTEUR	1			D
	70031-15000	MUFFLER ASSY.	SILENCIADOR COMPLETO	SILENCIEUX	1			D
11	70030-15110	MUFFLER BASE	SILENCIADOR BASE	SILENCIEUX BASE	1			D
12	70030-15130	MUFFLER PLATE	SILENCIADOR PLACA	SILENCIEUX PLAQUE	1			D
13	70031-15140	MUFFLER COVER	SILENCIADOR TAPA	SILENCIEUX COUVERCLE	1			D
14	70030-15160	MUFFLER GASKET	EMPAQUETADURA	JOINT	1			D
15	01010-05160	BOLT	PERNO	BOULON	2			D
16	70030-15170	LOCKWASHER	ARANDELA	RONDELLE D'ARRET	1			D
17	01213-04080	SCREW	TORNILLO	VIS	2			D
18	72141-15151	SCREEN	REJILLA	GRILLAGE	1			D

F-20

CRANKCASE, FAN COVER

CARTER, TAPA

CARTER DE MANIVELLE, CAGE DU VENTILATEUR

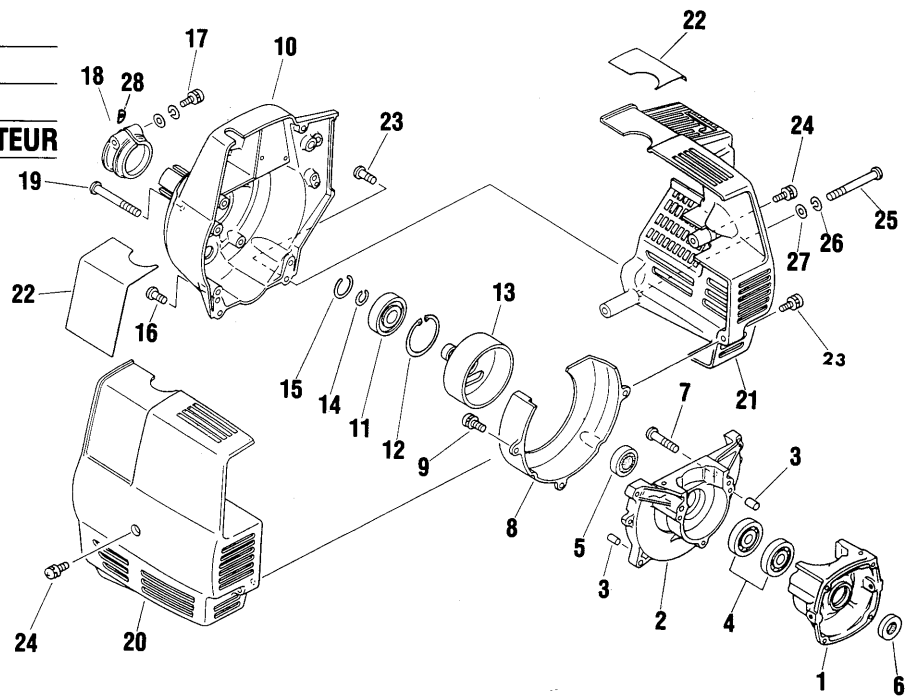

Index No. Indice	Part No. Pieza No. Numero	Part Name	Descripción	Nom de la pièce	Quant. Cant.	Serial No. Serie No.	Remarks Notas Note	Rank
1	70030-21110	CRANKCASE (S)	TAPA (S)	CARTER DE MANIVELLE	1			D
2	70030-21120	CRANKCASE (M)	TAPA (M)	CARTER DE MANIVELLE	1			D
3	70030-21140	DOWEL PIN	PASADOR	GOUPILLE	4			D
4	02030-06001	BEARING	COJINETTE	ROULEMENT	2			D
5	20000-21211	OIL SEAL	RETEN	JOINT ETANCHEITE	1			C
6	70030-21220	OIL SEAL	RETEN	JOINT ETANCHEITE	1			C
7	01020-05250	SCREW	TORNILLO	VIS	3			D
8	70030-21310	AIR DEFLECTOR	DEFLECTOR DE AIRE	DEFLECTEUR	1			D
9	01213-04120	SCREW	TORNILLO	VIS	3			D
	70030-31102	FAN COVER ASSY.	TAPA COMPLETA	CAGE DU VENTILATEUR	1			D
10	70030-31190	FAN COVER	TAPA	CAGE DU VENTILATEUR	1			D
11	02006-06201	BEARING	COJINETE	ROULEMENT	1			D
12	02432-32120	SNAP RING	ANILLO RETENEDOR	ANNEAU D'ARRET	1			C
13	70030-31120	CLUTCH DRUM	TAMBOR DEL EMBRAGUE	TAMBOUR EMBRAYAGE	1			D
14	20000-31140	SNAP RING	ANILLO RETENEDOR	ANNEAU D'ARRET	1			C
15	70030-31150	SNAP RING	ANILLO RETENEDOR	ANNEAU D'ARRET	1			C
16	01210-05160	SCREW	TORNILLO	VIS	3			D
17	01012-05250	SCREW	TORNILLO	VIS	1		REPLACES 01017-05250	D
18	70030-31310	CLAMP	ABRAZADERA	COLLET	1			D
19	01210-05500	BOLT	PERNO	BOULON	1			D
20	70030-32110	ENGINE COVER (L)	TAPA (L)	CULASSE (L)	1			D
21	70030-32121	ENGINE COVER (R)	TAPA (R)	CULASSE (R)	1			D
22	70030-32170	NAME PLATE	PLACA MARCA	PLAQUE IDENTIFICATION	1			—
23	01210-05160	SCREW	TORNILLO	VIS	3			D
24	01213-05250	SCREW	TORNILLO	VIS	3			D
25	01210-05500	SCREW	TORNILLO	VIS	2			D
26	01600-05131	SPRING WASHER	ARANDELA MUELLE	RONDELLE A RESSORT	2			D
27	01610-05080	WASHER	ARANDELA	RONDELLE	2			D
28	70030-31320	SHIM	ESPACIADOR	CALE	1			D

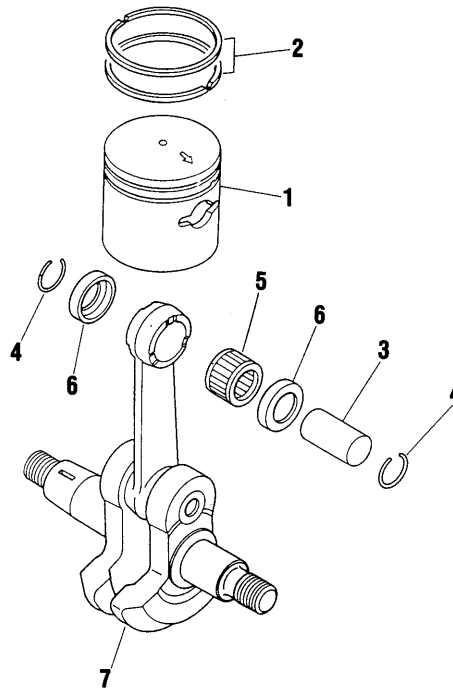
F-20**CRANKSHAFT, CLUTCH
CIGUEÑAL, EMBRAGUE
VILEBREQUIN, EMBRAYAGE**

Index No. Indice	Part No. Pieza No. Numero	Part Name	Descripción	Nom de la pièce	Quant. Cant.	Serial No. Serie No.	Remarks Notas Note	Rank
1	70030-41110	PISTON	PISTON	PISTON	1			C
2	70030-41210	PISTON RING	ANILLO PISTON	SEGMENT DE PISTON	2			B
3	70030-41310	PISTON PIN	PASADOR DEL PISTON	AXE DE PISTON	1			D
4	70030-41320	SNAP RING	ANILLO RETENEDOR	ANNEAU D'ARRET	2			B
5	70030-41330	NEEDLE BEARING (SE)	COJINETE, (SE)	ROULEMENT	1			C
6	70030-41340	THRUST WASHER	ARANDELA DE PRESION	RONDELLE A PRESSION	2			C
7	70030-42000	CRANKSHAFT ASSY.	CIGUEÑAL COMPLETO	VILEBREQUIN	1			D

F-20

IGNITION SYSTEM SISTEMA DE ENCENDIDO ALLUMAGE

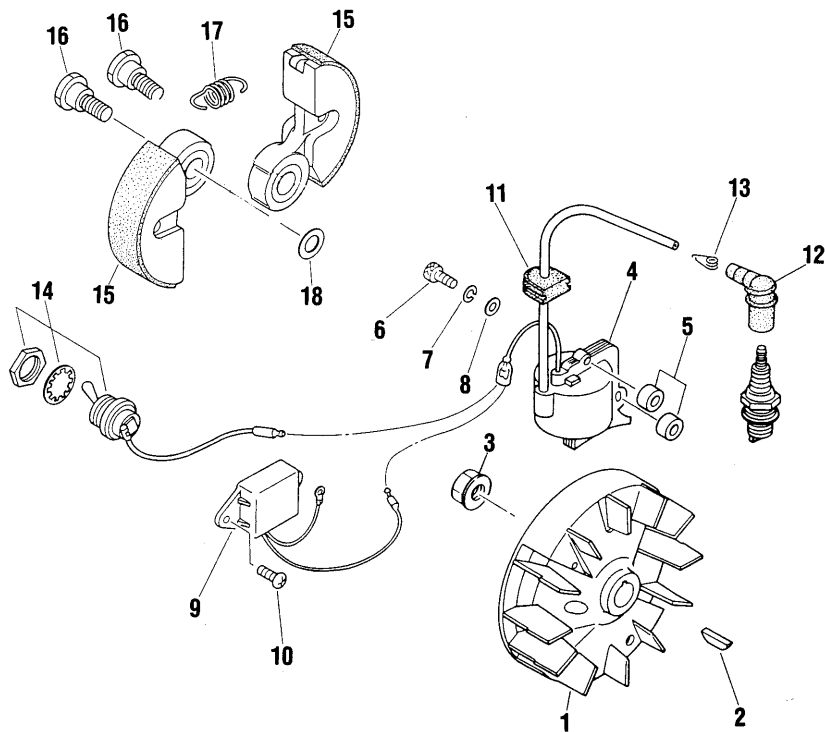

Index No. Indice	Part No. Pieza No. Numero	Part Name	Descripción	Nom de la pièce	Quant. Cant.	Serial No. Serie No.	Remarks Notas Note	Rank
1	70030-71201	ROTOR	VOLANTE	EXCENTRIQUE	1		MARKED D	D
2	22100-43210	KEY	CHAVETA	CLE-CLAVETTE	1			D
3	20035-71220	NUT	TUERCA	ECROU	1			C
4	70030-71610	COIL	CONDENSADOR	BOBINE	1			C
5	70030-71620	INSULATOR	AISLADOR	ISOLATEUR	2			C
6	01020-04260	BOLT	PERNO	BOULON	2			D
7	01600-04101	SPRING WASHER	ARANDELA MUELLE	RONDELLE A RESSORT	2			D
8	20010-71650	WASHER	ARANDELA	RONDELLE	2			D
9	70030-71711	UNIT	UNIDAD ELECTRONICA	UNITE	1			D
10	20000-31330	SCREW	TORNILLO	VIS	2			D
11	70030-72110	GROMMET	RETENEDOR	PASSE-CABLEE	1			D
12	20010-72221	PLUG CAP	TAPA DE BUJIA	BOUCHON	1			B
13	20000-72230	SPRING, PLUG	RESORTE DE BUJIA	RESSORT BOUGIE	1			B
		SPARK PLUG	BUJIA	BOUGIE	1		CHAMPION CJ-8	—
14	70030-74110	SWITCH	INTERRUPTOR	COMMUTATEUR	1			D
	70000-51103	CLUTCH SHOE ASSY.	ZAPATA DEL EMBRAGUE COMP.	SABOT D'ACC.	1			B
		CLUTCH SHOE	ZAPATA DEL EMBRAGUE	SABOT D'ACC.	2		ORDER 70000-51103	—
16	20000-51212	BOLT	PERNO	BOULON	2			D
17	70000-51220	SPRING	RESORTE	RESSORT	1			C
18	22100-71430	WASHER	ARANDELA	RONDELLE	2			D

F-20
CARBURETOR
CARBURADOR
CARBURATEUR

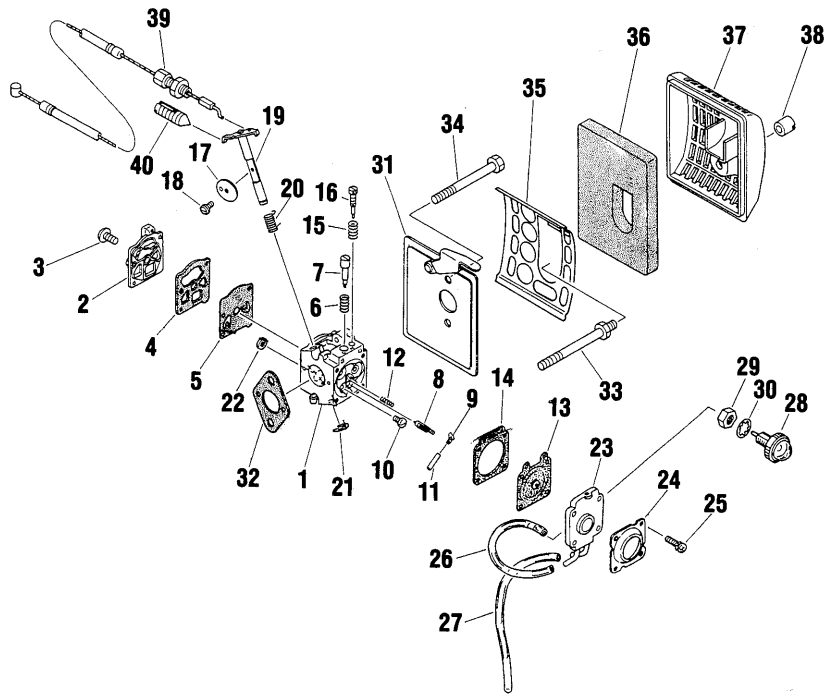

Index No. Indice	Part No. Pieza No. Numero	Part Name	Descripción	Nom de la pièce	Quant. Cant.	Serial No. Serie No.	Remarks Notas Note	Rank
	70030-81001	CARBURETOR ASSY.	CARBURADOR COMPLETO	CARBURATEUR	1			C
1		CARBURETOR BODY	CUERPO CARBURADOR	COUVERCLE CARBURATEUR	1		ORDER 70030-81001	—
2	70030-81120	PUMP COVER	TAPA DE BOMBA	COUVERCLE DE POMPE	1			D
3	22100-81130	SCREW	TORNILLO	VIS	1			D
4	22128-81140	GASKET	EMPAQUETADURA	JOINT	1			—
5	22128-81150	DIAPHRAGM	DIAFRAGMA	MEMBRANE	1			—
6	22100-81160	SPRING	RESORTE	RESSORT	1			D
7	70030-81171	L-NEEDLE	AGUJA BAJA VEL	AIGUILLE-L	1			D
8	22100-81310	NEEDLE VALVE	AGUJA VALVULA	POINTEAU	1		PART OF 22100-81200	D
9	22100-81230	LEVER	PALANCA	LEVIER	1		PART OF 22100-81200	D
10	22100-81240	SCREW	TORNILLO	VIS	1		PART OF 22100-81200	D
11	22100-81250	PIN	PASADOR	GOUPILLE	1		PART OF 22100-81200	D
12	22104-81270	SPRING	RESORTE	RESSORT	1		PART OF 22100-81200	D
13	22100-81260	DIAPHRAGM	DIAFRAGMA	MEMBRANES	1			—
14	22135-81290	GASKET	EMPAQUETADURA	JOINT	1			—
15	22100-81320	SPRING	RESORTE	RESSORT	1			D
16	70030-81330	H NEEDLE	AGUJA ALTA VEL	VIS DE REGLAGE	1			D
17	70030-81340	THROTTLE VALVE	VALVULA ACCELERADOR	SOUPAPE ACCELERATEUR	1			D
18	22100-81360	SCREW	TORNILLO	VIS	1		PART OF 22100-81200	D
19	70030-81370	SHAFT	EJE	AXE	1			D
20	70030-81410	SPRING	RESORTE	RESSORT	1			D
21	70030-81390	E RING	SEGURO DEL PASADOR	JOINT TORIQUE (E)	1			C
22	70030-81380	SCREEN	FILTRO	GRILLAGE	1			B
23	22135-81520	STARTER BODY	ARRANCADOR	BOITIER DU DEMARREUR	1			D
24	22135-81510	COVER	TAPA	COUVERCLE	1			D
25	22135-81530	SCREW	TORNILLO	VIS	4			D
26	22135-81540	CONNECTOR TUBE	TUBO CONNECTOR	TUYAU DE CONNECTION	1			C
27	70030-81550	DRAIN TUBE	TUBO DE DESBORDE	TUYAU DU DRAIN	1			C
	22135-81600	PRIMER ASSY.	CEBADOR	AMORCE	1			C
28	22135-81610	PRIMING PUMP	BOMBA DEL CEBADOR	POMPO-AMORCE	1			D
29	01511-10060	NUT	TUERCA	ECROU	1			D
30	01602-01000	LOCK WASHER	ARANDELA	RONDELLE D'ARRET	1			D

Index No. Índice	Part No. Pieza No. Numero	Part Name	Descripción	Nom de la pièce	Quant. Cant.	Serial No. Serie No.	Remarks Notas Note	Rank
31	70030-82101	CHOKE ASSY.	ESTRANGULADOR COMPLETO	VOGET D'AIR	1			C
32	70030-82210	GASKET, CARBURETOR	EMPAQUETADURA	JOINT	1			C
33	70030-82220	BOLT	PERNO	BOULON	1			D
34	01010-05500	BOLT	PERNO	BOULON	1			D
35	70030-82310	AIR CLEANER PLATE	PLACA PROTECTORA	PLAQUE DU FILTRE-AIR	1			C
36	70030-82320	AIR FILTER	FILTRO	FILTRE A AIR	1			B
37	70030-82330	AIR CLEANER COVER	TAPA DEL FILTRO	COUVERCLE FILTRE-AIR	1			C
38	70030-82340	NUT	TUERCA	ECROU	1			B
39	70030-83110	THROTTLE CABLE	CABLE	CABLE D'ACCELERATEUR	1			D
40	70030-83210	ADJUST, SCREW	TORNILLO DE AJUSTE	VIS D'AJUST	1			D
	22135-81920	GASKET KIT	JUEGO DE EMPAQUETADURA	ENSEMBLE DE JOINTS	1			B
4	22128-81140	GASKET	EMPAQUETADURA	JOINT	1			—
14	22135-81290	GASKET	EMPAQUETADURA	JOINT	1			—
	22128-81910	DIAPHRAGM	JUEGO DE DIAFRAGMA	JEU DE MEMBRANES	1			B
5	22128-81150	DIAPHRAGM	DIAFRAGMA	MEMBRANES	1			—
13	22100-81260	DIAPHRAGM	DIAFRAGMA	MEMBRANES	1			—
	22100-81200	KWIK KIT	KIT	ENSEMBLE DE PIECES	1			B
8		NEEDLE VALVE	AGUJA VALVULA	POINTEAU	1		ORDER 22100-81200	D
9		LEVER	PALANCA	LEVIER	1		ORDER 22000-81200	D
10		SCREW	TORNILLO	VIS	1		ORDER 22000-81200	D
11		PIN	PASADOR	GOUPILLE	1		ORDER 22000-81200	D
12		SPRING	RESORTE	RESSORT	1		ORDER 22000-81200	D
18		SCREW	TORNILLO	VIS	1		ORDER 22000-81200	D
		SCREEN	FILTRO	GRILLAGE	1		ORDER 22100-81200	D

F-20
STARTER
ARRANCADOR
DEMARREUR

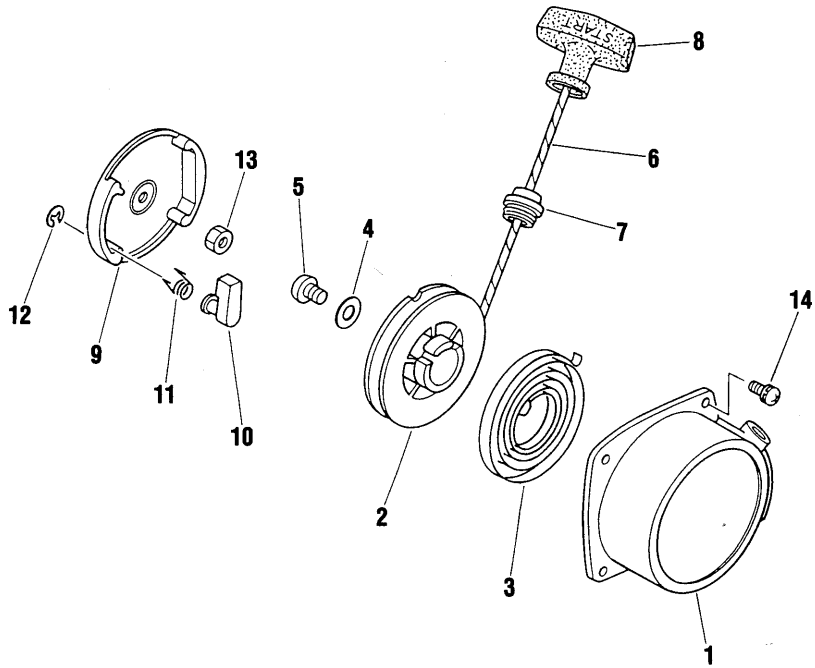

Index No. Indice	Part No. Pieza No. Numero	Part Name	Descripción	Nom de la pièce	Quant. Cant.	Serial No. Serie No.	Remarks Notas Note	Rank
	70030-75100	STARTER SUB ASSY.	ARRANCADOR	DEMARREUR COMPLET	1			D
1	70030-75110	STARTER CASE	TAPA DEL ARRANCADOR	BOITIER DEMARREUR	1			D
2	70030-75120	REEL	TAMBOR	BOBINE	1			D
3	70030-75130	RECOIL SPRING	RESORTE ESPIRAL	RESSORT	1			B
4	70030-75140	WASHER	ARANDELA	RONDELLE	1			D
5	70030-75150	SCRÉW	TORNILLO	VIS	1			D
6	70030-75160	ROPE	CUERDA	CORDE	1			D
7	70030-75170	ROPE GUIDE	GUIA DEL CORDON	CORDE-GUIDE	1			D
8	20000-75190	STARTER KNOB	ASIDERO	POIGNEE DE DEMARREUR	1			D
	70030-75200	PULLEY SUB ASSY.	POLEA COMPLETO	POULIE	1			D
9		PULLEY	POLEA	POULIE	1		ORDER 70030-75200	—
10	70030-75220	RATCHET	TRINQUETE	ROCHET	1			C
11	70030-75230	RETURN SPRING	RESORTE	RESSORT DE RETOUR	1			C
12	70030-75240	E RING	SEGURO DEL PASADOR	JOINT TORIQUE (E)	1			C
13	20035-43230	NUT	TUERCA	ECROU	1			D
14	01213-04120	SCREW	TORNILLO	VIS	4			D

F-20

FUEL TANK

TANQUE DEL COMBUSTIBLE

RESERVOIR A ESSENCE

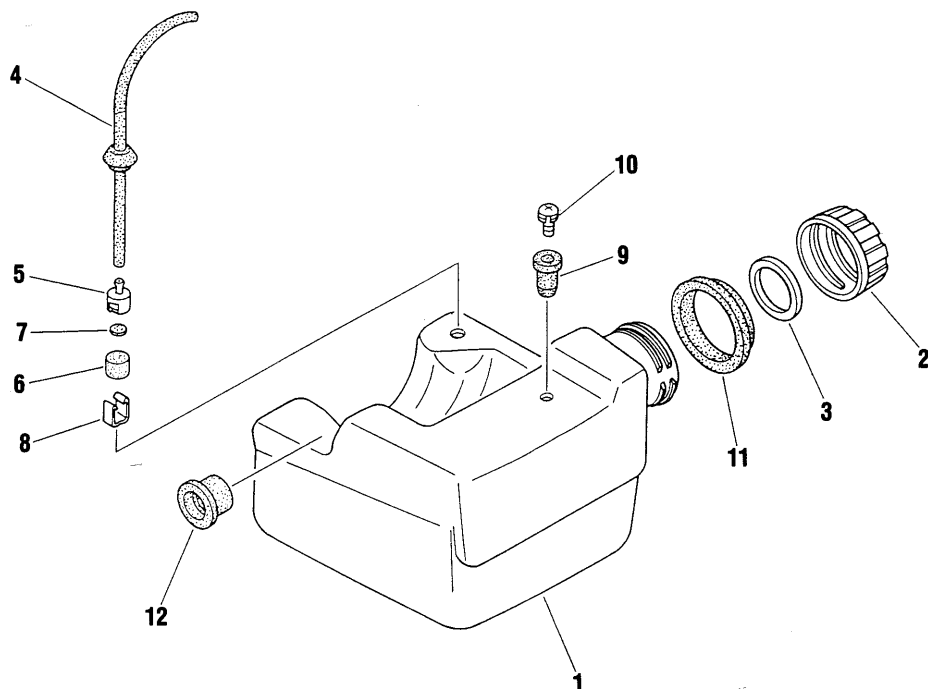

Index No. Indice	Part No. Pieza No. Numero	Part Name	Descripción	Nom de la pièce	Quant. Cant.	Serial No. Serie No.	Remarks Notas Note	Rank
	70030-85000	FUEL TANK ASSY.	TANQUE DE COMBUSTIBLE COMPLETO	RESERVOIR A ESSENCE	1			D
1	70030-85110	FUEL TANK	TANQUE DE COMBUSTIBLE	RESERVOIR A ESSENCE	1			D
	70030-85200	FUEL CAP ASSY.	TAPA COMPLETA	BOUCHON D'ESSENCE	1			C
2		FUEL CAP	TAPA	BOUCHON D'ESSENCE	1		ORDER 70030-85200	—
3	70030-85220	GASKET, CAP	EMPAQUETADURA	JOINT	1			C
4	70030-85300	FUEL TUBE SUB ASSY.	TUBERIA COMPLETA	JUYAU A ESSENCE	1			A
	70030-85400	FUEL FILTER ASSY.	FILTRO COMPLETO	FILTRE A ESSENCE	1			C
5	70030-85410	WEIGHT, FILTER	PESA	ANCRE, A ESSENCE	1			D
6	70030-85420	FILTER (A)	FILTRO (A)	FILTRE (A)	1			B
7	70030-85430	FILTER (B)	FILTRO (B)	FILTRE (B)	1			B
8	70030-85440	CLIP, FILTER	SUJETADOR	ATTACHE FILTRE	1			C
	70030-85500	BREATHER ASSY.	SISTEMA DE VENTILACION	PRISE D'AIR	1			C
9		BREATHER BODY	TAPON DE VENTILACION	PRISE D'AIR	1		ORDER 70030-85500	—
10	01211-03060	SCREW	TORNILLO	VIS	1			D
11	70030-86110	CUSHION	AMORTIGUADOR	COUSSIN	1			C
12	70030-86120	CUSHION	AMORTIGUADOR	COUSSIN	1			C

F-20

OUTER TUBE TUBO EXTERIOR TUBE

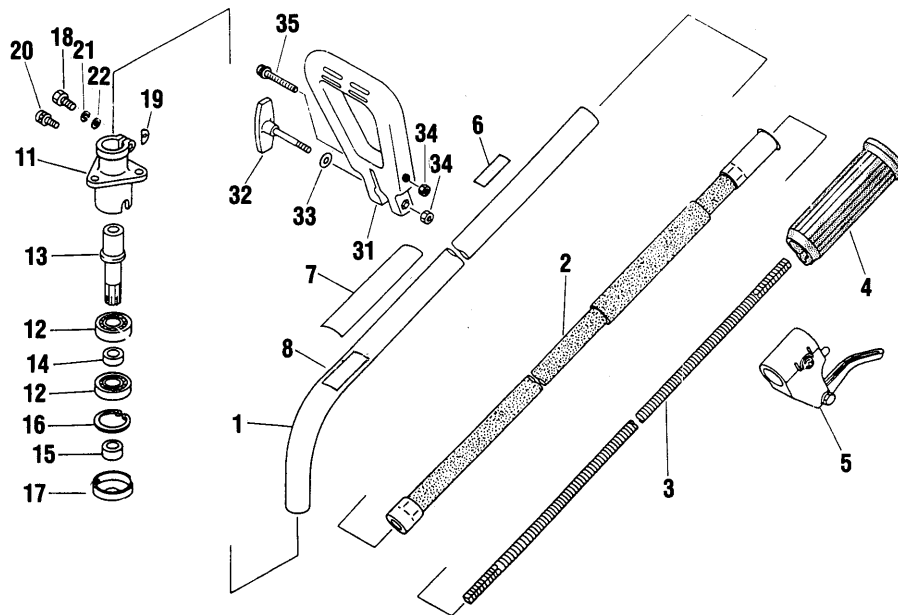

Index No. / Indice	Part No. / Pieza No. / Numero	Part Name	Descripción	Nom de la pièce	Quant. / Cant.	Serial No. / Serie No.	Remarks / Notas / Note	Rank
	72030-12001	OUTER TUBE ASSY.	TUBO COMPLETO	TUBE EXT. C	1			B
1	72030-12111	OUTER TUBE	TUBO	TUBE	1			D
2	72030-12120	FLEXIBLE LINER	CUBIERTA FLEXIBLE	RECOUVREMENT FLEXIBLE	1			D
3	72030-12410	FLEXIBLE SHAFT	EJE FLEXIBLE	AXE FLEXIBLE	1			C
4	72030-12131	GRIP	MANILLA	POIGNEE	1			D
5	72030-12310	THROTTLE LEVER	ACELERADOR	LEVIER ACC.	1			D
6	72017-12150	HANDLE LABEL	ETIQUETA, MANGO	PLAQUE	1			—
7	72005-12510	NAME PLATE	PLACA, NOMBRE	PLAQUE IDENTIFICATION	1			—
8	19402-00024	CAUTION LABEL	PLACA, AVISO	PLAQUE ADVERTISSEMENT	1			—
	72030-13101	GEAR CASE ASSY.	CAJA DE ENGRANAJES COMPLETA	BOITIER DE L'AXE	1			D
11	72030-13111	GEAR CASE	CAJA DE ENGRANAJES	BOITIER-AXE	1			D
12	02006-06001	BEARING	COJINETE	ROULEMENT	2			D
13	72030-13120	SHAFT	EJE	AXE	1			D
14	72030-13130	COLLAR (A)	COLLAR (A)	COLLET (A)	1			D
15	72030-13140	COLLAR (B)	COLLAR (B)	COLLET (B)	1			D
16	02432-28120	SNAP RING	ANILLO RETENCION	ANNEAU ARRET	1			C
17	72030-13151	HOLDER	SOPORTE	ATTACHE	1			D
18	01020-05250	BOLT	PERNO	BOULON	1		REPLACES 01017-05250	D
19	22000-13420	SHIM	ESPACIADOR	CALE	1			D
20	01213-05100	SCREW	TORNILLO	VIS	1			D
21	01600-05131	SPRING WASHER	ARANDELA MUELLE	RONDELLE A RESSORT	1			D
22	01610-05080	WASHER	ARANDELA	RONDELLE	1			D
	72030-14101	HANDLE ASSY.	MANGO COMPLETO	POIGNEE	1		REPLACES 72030-14100	D
31		HANDLE	MANGO	POIGNEE	1		ORDER 72030-14101	—
32	72030-14120	KNOB	ASIDERO	BOUTON	1			D
33	72030-14130	WASHER	ARANDELA	RONDELLE	1			D
34	01500-06051	NUT	TUERCA	ECROU	2			D
35	72030-14141	SCREW	TORNILLO	VIS	1			D

F-20

ACCESSORIES

ACCESORIOS

ACCESSOIRES

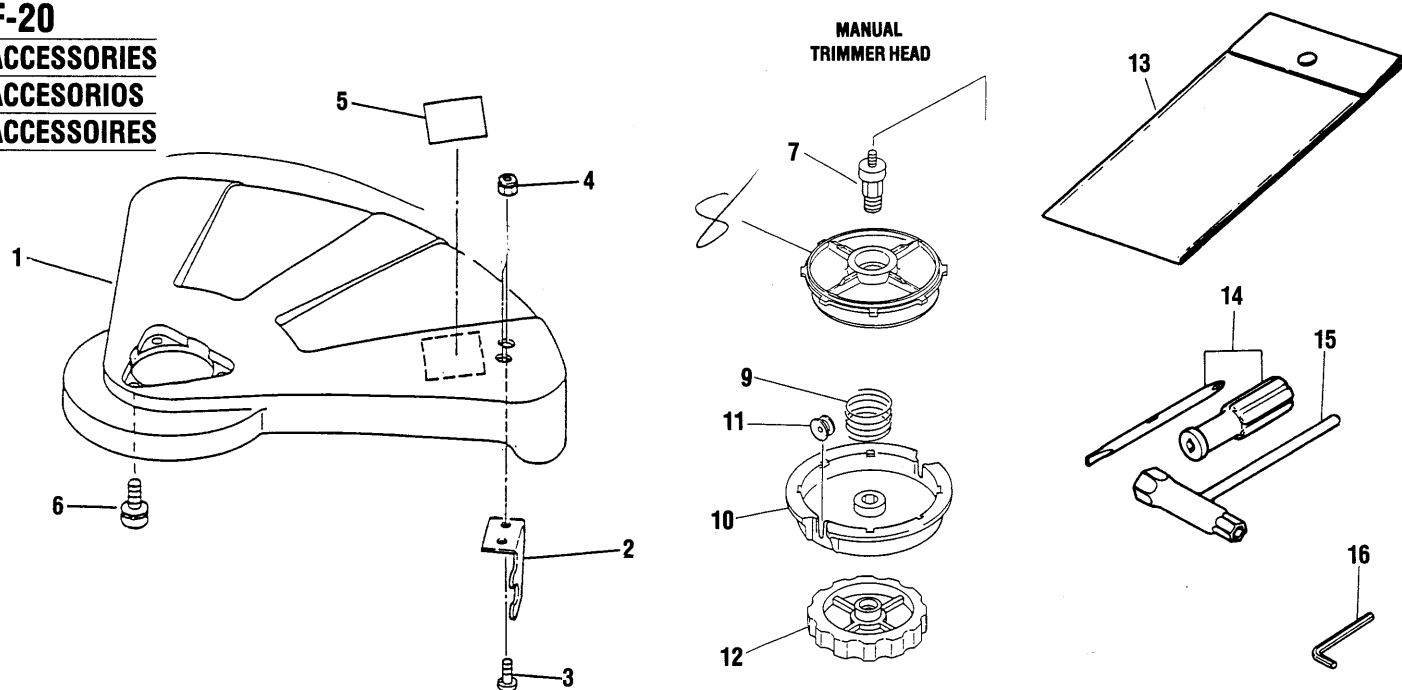

Index No. Índice	Part No. Pieza No. Numero	Part Name	Descripción	Nom de la pièce	Quant. Cant.	Serial No. Serie No.	Remarks Notas Note	Rank
	72030-16005	GUARD ASSY.	PROTECTOR COMPLETO	PROTECTEUR	1			D
1	72030-16113	GUARD	PROTECTOR	PROTECTEUR	1			—
2	72030-16121	CUTTER	CORTADOR	DESSOUS	1			D
	11204-04160	SCREW	TORNILLO	VIS	2			D
4	72030-16150	NYLON NUT	TUERCA, NYLON	ECROU	2			D
5	72030-16140	CAUTION PLATE	PLACA, AVISO	PLAQUE ADVERTISSEMENT	1			D
6	01213-05160	SCREW	TORNILLO	VIS	3			D
	72030-15102	MANUAL TRIMMER HEAD	CABEZAL	TEKE DE COUPE	1	30076007		D
7	72030-15111	SHAFT BOLT	ADAPTADOR	BOULON-AXE	1			D
8	72030-15122	INNER SPOOL	CARRETE EXTERNO	BOBINE	1			D
9	72030-15171	SPRING	CORDÓN	CABLE	1			A
10	72030-15141	SPOOL HOUSING	CUERPO	CAGE DE LA BOBINE	1			D
11	72030-15150	EYELET	BOQUILLAS	PASSE-CABLE	2			C
12	72030-15161	KNOB	TUERCA	BOUTON	1			D
	72030-91000	TOOL SET	JUEGO DE HERRAMIENTAS	JUE OUTILS	1			D
13	72030-91110	TOOL BAG	BOLSA DE HERRAMIENTAS	SAC A OUTILS	1			—
14	22100-91150	SCREW DRIVER	DESTORNILLADOR	TOURNEVIS	1			—
15	22000-91181	PLUG WRENCH	LLAVE	CLE A BOUGIE	1			D
16	22100-91561	WRENCH (4)	LLAVE (4)	CLE (4)	1			D

F-20

ACCESSORIES

ACCESORIOS

ACCESSOIRES

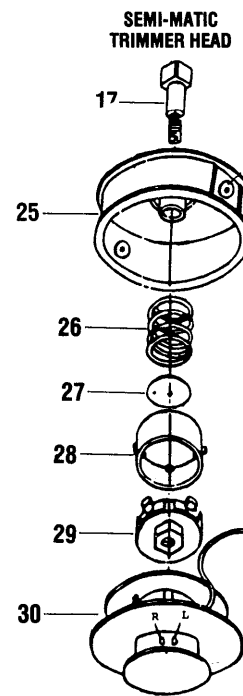
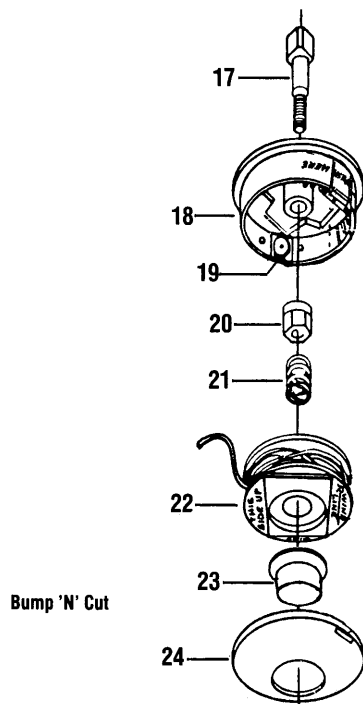

Index No. Indice	Part No. Pieza No. Numero	Part Name	Descripción	Nom de la pièce	Quant. Cant.	Serial No. Serie No.	Remarks Notas Note	Rank
	72078-15100	BUMP 'N' CUT TRIMMER HEAD	PODADORA	TETE DE COUPE	1			D
17	72005-92710	SHAFT BOLT	ADAPTADOR	BOULON-AXE	1			D
18	72078-15220	HOUSING	CUERPO	CAGE	1			D
19	72005-92630	EYELET	BOQUILLAS	PASSE-CABLE	1			D
20	72418-15130	NUT	TUERCA	ECROU	2			D
21	72078-15240	SPRING	RESORTE	RESSORT	1			C
22	72078-15260	SPOOL	CARRETE	BOBINE	1			A
23	72078-15280	BUTTON	BOTON	BOUTON	1			C
24	72078-15290	COVER	TAPA	COUVERCLE	1			A
	99909-15600	SEMI-MATIC TRIMMER HEAD	CABEZAL	TETE DE COUPE	1			A
17	72005-92710	SHAFT BOLT	ADAPTADOR	BOULON-AXE	1			C
25	99909-15510	SPOOL HOUSING	CUERPO	CAGE DE LA BOBINE	1			D
26	99909-15520	SPRING	RESORTE	RESSORT	1			C
27	99909-15530	WASHER	ARANDELA	RONDELLE	1			C
28	99909-15540	OUTER DRIVE	PROTECTOR EXTERNO	ESPACEUR EXT	1			C
29	99909-15550	INNER CAM	TUERCA INTERNA	ESPACEUR INT	1			C
30	99909-15560	INNER SPOOL	CARRETTE EXTERNO	BOBINE	1			C

shindaiwa

Shindaiwa, Inc.
P.O. Box 1090, Tualatin, OR 97062
11975 S.W. Herman Rd., Sherwood, OR 97140

SHIN-DAIWA KOGYO CO., LTD.

Head Office: 35 Shin-Ujigami, Oaza, Chiyoda-Cho, Yamagata-Gun,
Hiroshima, 731-14 Japan
Phone: 082672-6011 — TLX: 665871

STOCK NO. 20170-7
SUPERSEDES NO. 20064-5
11/87

PRINTED IN U.S.A.

